

MODEL

EMT6160Z
embraco
Nidec

APPROVALS



ENGINEERING CODE
 513306230



APPROVED REFRIGERANT
 R-134a

POWER SUPPLY
 220-240 V 50 Hz

STANDARD CONDITIONS
 ASHRAE

APPLICATION
 HBP

COOLING CAPACITY
 732 W (HBP)

EFFICIENCY
 2.44 W/W (HBP)

MOTOR TYPE
 CSIR

STARTING TORQUE
 HST

DATA
General Data

Type	Hermetic reciprocating
Technology Type	On-Off
Displacement	6.76 cm ³
Compressor Cooling	Fan/NotControlled/220
Expansion Device	Capillary Tube or Expansion Valve
Horse Power	1/4 hp
Power Supply	220-240 V 50 Hz
Evaporating Temperature Range	-15 °C to 10 °C

Electrical Data

Motor type	CSIR
Starting Torque	HST
Start Winding Resistance	19.15 Ω at 25° C
Run Winding Resistance	11.3 Ω at 25° C
Rated Load Amperage (RLA) at 50 Hz	1.35 A

Mechanical Data

Oil Charge	180 ml
Oil Type Configuration	ESTER
Oil Type Viscosity	ISO22
Weight	7.75 Kg

Electrical Components

	Description
Start Capacitor	64-77 Uf / 330 V
Starting Device	Relay QL2-4.35 ***
Motor Protection	DRB180L61AXF

External Characteristics

Tray Holder	Yes	
Connector	Internal Diameter	Shape
Suction	6.1 mm	Slanted 42° up + 45° to Back/Copper
Discharge	4.94 mm	Slanted parallel BP+24° to Back/Copper
Process	6.1 mm	Slanted 45° up + 45° to Back/Copper

PERFORMANCE

Rated Points

Condensing Temperature	Evaporating Temperature	Cooling Capacity	Power Consumption	Current	Gas Flow Rate	Efficiency
54.40°C	7.20°C	732 W	300 W	1.76 A	16.21 kg/h	2.44 W/W

Test Condition: ASHRAEHBP46, Fan/NotControlled/220, Return Gas 35°C, Evaporation 7.20°C, Condensing 54.40°C, Ambient 35°C, Liquid 46.1°C, Subcooling 8.3K. Data in accordance to EN

12900:2013 and AHRI 540:2015 polynomial equation and uncertainty guidance.

Performance Curve Data

Condensing Temperature 35°C

Evaporating Temperature °C	Cooling Capacity W	Power W	Current A	Gas Flow Rate kg/h	Efficiency W/W
-15	432	173	1.35	7.98	2.51
-10	542	188	1.4	10.04	2.88
-5	674	205	1.45	12.52	3.28
0	825	224	1.5	15.40	3.68
5	993	244	1.57	18.64	4.07
10	1176	266	1.65	22.22	4.42

Test Condition: ASHRAEHBP46, Fan/NotControlled/220, Return Gas 35°C, Ambient 35°C, Subcooling 8.3K. Data in accordance to EN 12900:2013 and AHRI 540:2015 polynomial equation and uncertainty guidance.

Condensing Temperature 45°C

Evaporating Temperature °C	Cooling Capacity W	Power W	Current A	Gas Flow Rate kg/h	Efficiency W/W
-15	357	182	1.38	7.12	1.97
-10	448	201	1.43	8.95	2.23
-5	558	222	1.49	11.20	2.52
0	686	244	1.56	13.85	2.81
5	831	268	1.64	16.87	3.1
10	989	293	1.73	20.23	3.38

Test Condition: ASHRAEHBP46, Fan/NotControlled/220, Return Gas 35°C, Ambient 35°C, Subcooling 8.3K. Data in accordance to EN 12900:2013 and AHRI 540:2015 polynomial equation and uncertainty guidance.

Condensing Temperature 55°C

Evaporating Temperature °C	Cooling Capacity W	Power W	Current A	Gas Flow Rate kg/h	Efficiency W/W
-15	284	193	1.41	6.18	1.47
-10	353	215	1.47	7.72	1.65
-5	441	238	1.55	9.68	1.86
0	546	262	1.63	12.04	2.08
5	666	288	1.72	14.77	2.31
10	799	316	1.82	17.85	2.53

Test Condition: ASHRAEHBP46, Fan/NotControlled/220, Return Gas 35°C, Ambient 35°C, Subcooling 8.3K. Data in accordance to EN 12900:2013 and AHRI 540:2015 polynomial equation and uncertainty guidance.

Operating Envelope

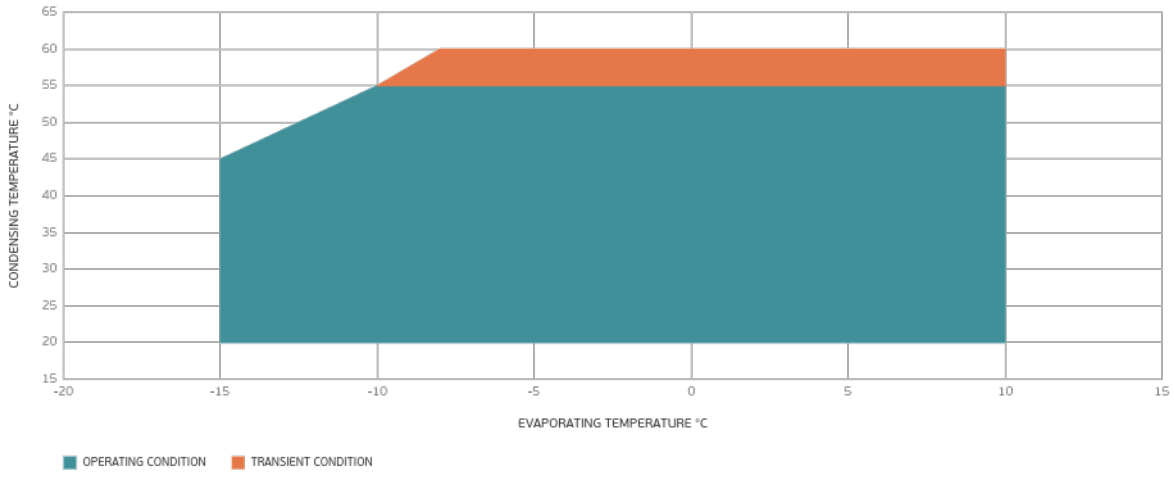

External Dimensions

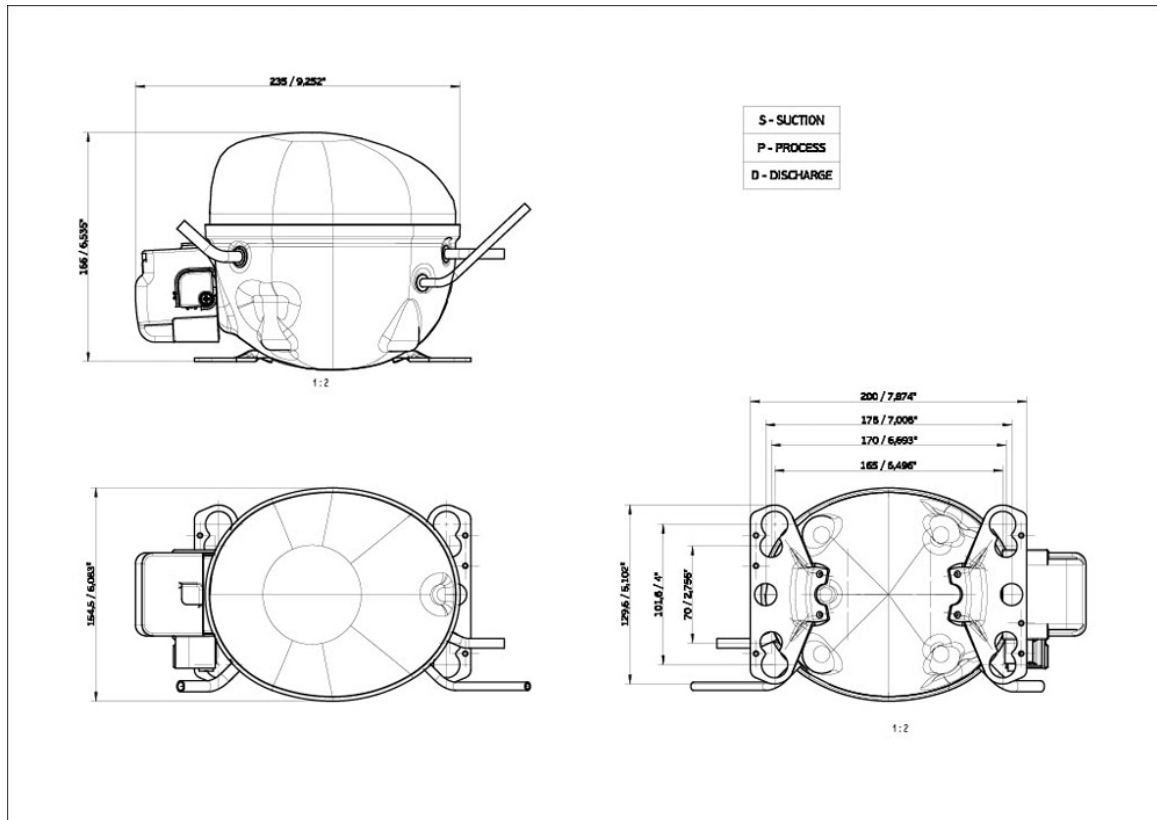

Wiring Diagram

