

Technical Data Sheet

Compressor model **GX21TB**
 Voltage **220-240V 50Hz ~1**
 Refrigerant **R134a**

APPLICATION

COMPRESSOR

MOTOR

Application	High-Medium Back Pressure	Displacement	20,72 cm ³	Approximate Power	5/8 hp
Refrigerant	R134a	Diameter	34,93 mm	Voltage/Frequency	220V 50Hz
Evaporating Temp.	-25,0 to 10,0	Stroke	21,62 mm	Voltage range	187-264 V
Expansion	Capillar/Valve	Net Weight	17,00 Kg	Type	CSIR
Comp. Cooling	Fan cooled	Oil type	ISO VG 46 ESTER	Phase number	1 P
Max. ambient temp.	43,0	Oil charge	500 cm ³	Locked rotor current	26,00 A
				Main W. resist. at 25°C	2,70
				Start W. resist. at 25°C	22,50

NOMINAL PERFORMANCE

	ASHRAE	CECOMAF
Cooling Capacity	1.595 kcal/h	1.564 W
COP	2,18 W/W	1,92 W/W
EER	1,88 kcal/Wh	1,66 kcal/Wh
Input Power	850 W	815 W
Current	5,30 A	5,16 A

APPROVALS



TEST CYCLE CONDITIONS

	ASHRAE HMBP (D)	CECOMAF HMBP (C)
Evaporating temp.	7,2 °C	5,0 °C
Condensing temp.	55,0 °C	55,0 °C
Liquid temp.	46,0 °C	55,0 °C
Ambient temp.	35,0 °C	32,0 °C
Suction temp.	35,0 °C	32,0 °C
Voltage/Frequency	220 V 50 Hz	220 V 50 Hz

ELECTRICAL COMPONENTS

Starting capacitor	72- 88 µF 330 V			
Relay	Option 1			
Reference	2014 180.			
Pick-Up	16,70 A			
Drop-Out	14,00 A			
Protector	Option 1	Option 2		
Reference	MRA38128	T0535		
Current	17,00 A	17,00 A		
Time check	7,5-14 seg	7,5-14 seg		
Disc temp. (Open/Close)	105,00 / 52,00 °C	105,00 / 52,00 °C		

ASHRAE

Tc	Te	Cooling Capacity kcal/h	Consumption W	Current A	COP W/W	EER kcal/Wh
40	-25	420	385	3,70	1,27	1,09
40	-20	576	438	3,85	1,53	1,32
40	-15	762	491	4,00	1,81	1,55
40	-10	979	544	4,17	2,09	1,80
40	-5	1.227	598	4,34	2,39	2,05
40	0	1.505	652	4,53	2,69	2,31
40	5	1.814	706	4,73	2,99	2,57
40	7,2	1.960	730	4,82	3,12	2,68
40	10	2.154	761	4,94	3,29	2,83
45	-25	382	385	3,70	1,15	0,99
45	-20	525	444	3,86	1,37	1,18
45	-15	698	503	4,04	1,61	1,39
45	-10	902	563	4,23	1,86	1,60
45	-5	1.137	623	4,43	2,12	1,83
45	0	1.402	683	4,64	2,39	2,05
45	5	1.698	743	4,87	2,66	2,29
45	7,2	1.838	770	4,97	2,78	2,39
45	10	2.025	804	5,11	2,93	2,52
50	-25	343	385	3,70	1,04	0,89
50	-20	473	450	3,88	1,22	1,05
50	-15	634	516	4,08	1,43	1,23
50	-10	825	581	4,29	1,65	1,42
50	-5	1.047	647	4,51	1,88	1,62
50	0	1.299	714	4,76	2,12	1,82
50	5	1.582	781	5,02	2,36	2,03
50	7,2	1.717	810	5,13	2,46	2,12
50	10	1.896	848	5,29	2,60	2,24
55	-25	305	385	3,70	0,92	0,79
55	-20	422	456	3,90	1,08	0,92
55	-15	570	528	4,12	1,25	1,08
55	-10	748	600	4,35	1,45	1,25
55	-5	957	672	4,60	1,66	1,42
55	0	1.196	745	4,88	1,87	1,61
55	5	1.466	818	5,17	2,09	1,79
55	7,2	1.595	850	5,30	2,18	1,88
55	10	1.767	891	5,48	2,31	1,98
60	-25	267	385	3,70	0,81	0,69
60	-20	371	463	3,92	0,93	0,80
60	-15	506	540	4,15	1,09	0,94
60	-10	671	619	4,41	1,26	1,08
60	-5	867	697	4,69	1,45	1,24
60	0	1.093	776	5,00	1,64	1,41
60	5	1.350	855	5,32	1,84	1,58
60	7,2	1.473	890	5,47	1,93	1,66
60	10	1.638	935	5,67	2,04	1,75
65	-25	228	385	3,70	0,69	0,59
65	-20	320	469	3,93	0,79	0,68
65	-15	441	553	4,19	0,93	0,80
65	-10	594	637	4,48	1,08	0,93
65	-5	777	722	4,79	1,25	1,08
65	0	990	807	5,12	1,43	1,23
65	5	1.235	892	5,48	1,61	1,38
65	7,2	1.352	930	5,65	1,69	1,45
65	10	1.509	978	5,87	1,79	1,54

COMPRESSOR DIMENSIONS

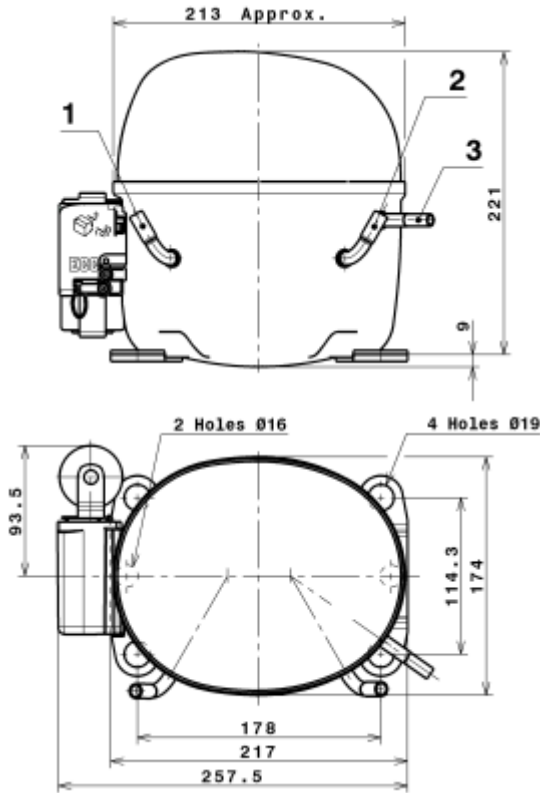

DESIGNATION	INTERNAL DIAM.
1 Service	8,1 mm
2 Suction	8,1 mm
3 Discharge	6,5 mm

WIRING DIAGRAMS AND ELECTRICAL ASSEMBLY

CSIR CONNECTION

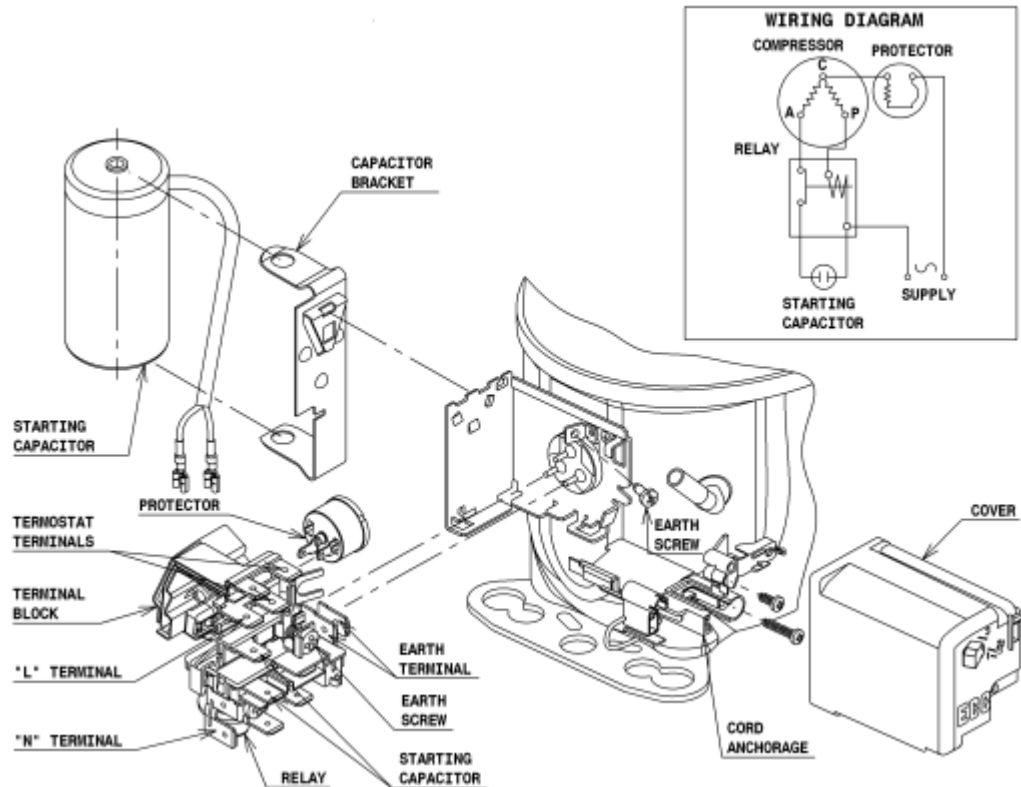

Technical Data Sheet

FIXINGS

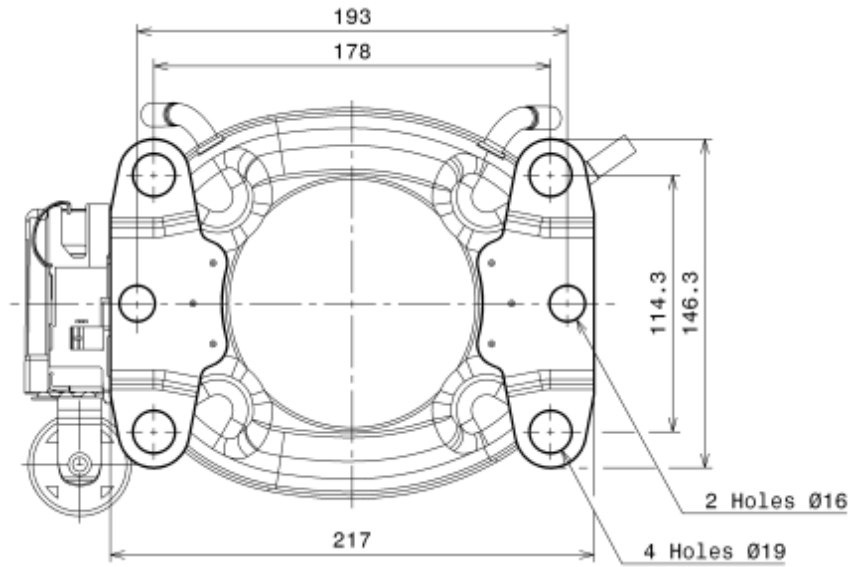

SILENT BLOCKS (MOUNTING ACCESSORIES)

STANDARD

D.19 holds net (203.2x122.2)

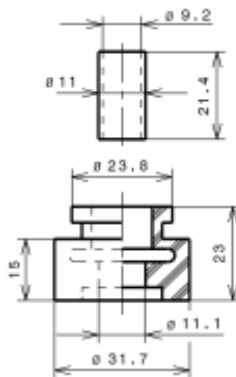

SOA

SOA R134a HMBP

