



APPROVALS



ENGINEERING CODE
513306045

APPROVED REFRIGERANT
R-134a

POWER SUPPLY
220-240 V 50 Hz

STANDARD CONDITIONS
ASHRAE

APPLICATION
HBP

COOLING CAPACITY
422 W (HBP)

EFFICIENCY
2.65 W/W (HBP)

MOTOR TYPE
CSIR

STARTING TORQUE
HST

DATA

General Data

Type	Hermetic reciprocating
Technology Type	On-Off
Displacement	3.97 cm ³
Compressor Cooling	Static/NotControlled/220
Expansion Device	Capillary Tube or Expansion Valve
Horse Power	1/7 hp
Power Supply	220-240 V 50 Hz
Evaporating Temperature Range	-15 °C to 10 °C

Electrical Data

Motor type	CSIR
Starting Torque	HST
Start Winding Resistance	18.1 Ω at 25° C
Run Winding Resistance	16.25 Ω at 25° C
Rated Load Amperage (RLA) at 50 Hz	1.35 A

Mechanical Data

Oil Charge	180 ml
Oil Type Configuration	ESTER
Oil Type Viscosity	ISO22
Weight	7.52 Kg

Electrical Components

	Description
Starting Device	Relay MTRP-0036*
Start Capacitor	64-77 Uf / 280 V
Motor Protection	T0043/G5

External Characteristics

Tray Holder	Yes	
Connector	Internal Diameter	Shape
Suction	6.1 mm	Slanted 42° up + 45° to Back/Copper
Discharge	4.94 mm	Slanted parallel BP+24° to Back/Copper
Process	6.1 mm	Slanted 45° up + 45° to Back/Copper

PERFORMANCE

Rated Points

Condensing Temperature	Evaporating Temperature	Cooling Capacity	Power Consumption	Current	Gas Flow Rate	Efficiency
54.40°C	7.20°C	422 W	159 W	0.96 A	9.33 kg/h	2.65 W/W

Test Condition: ASHRAEHBP46, Static/NotControlled/220, Return Gas 35°C, Evaporation 7.20°C, Condensing 54.40°C, Ambient 35°C, Liquid 46.1°C, Subcooling 8.3K. Data in accordance to EN

12900:2013 and AHRI 540:2015 polynomial equation and uncertainty guidance.

Performance Curve Data

Condensing Temperature 35°C

Evaporating Temperature °C	Cooling Capacity W	Power W	Current A	Gas Flow Rate kg/h	Efficiency W/W
-15	252	98	0.82	4.66	2.57
-10	316	106	0.84	5.85	2.97
-5	392	113	0.85	7.28	3.45
0	480	120	0.86	8.97	4.01
5	581	126	0.87	10.91	4.62
10	694	131	0.89	13.12	5.3

Test Condition: ASHRAEHBP46, Static/NotControlled/220, Return Gas 35°C, Ambient 35°C, Subcooling 8.3K. Data in accordance to EN 12900:2013 and AHRI 540:2015 polynomial equation and uncertainty guidance.

Condensing Temperature 45°C

Evaporating Temperature °C	Cooling Capacity W	Power W	Current A	Gas Flow Rate kg/h	Efficiency W/W
-15	205	101	0.82	4.09	2.03
-10	255	112	0.85	5.11	2.28
-5	318	122	0.87	6.39	2.6
0	393	132	0.89	7.93	2.99
5	480	141	0.91	9.75	3.42
10	579	149	0.94	11.85	3.88

Test Condition: ASHRAEHBP46, Static/NotControlled/220, Return Gas 35°C, Ambient 35°C, Subcooling 8.3K. Data in accordance to EN 12900:2013 and AHRI 540:2015 polynomial equation and uncertainty guidance.

Condensing Temperature 55°C

Evaporating Temperature °C	Cooling Capacity W	Power W	Current A	Gas Flow Rate kg/h	Efficiency W/W
-15	166	107	0.83	3.61	1.55
-10	201	120	0.86	4.39	1.68
-5	249	131	0.89	5.46	1.9
0	309	143	0.92	6.81	2.16
5	381	154	0.95	8.45	2.48
10	465	165	0.99	10.38	2.82

Test Condition: ASHRAEHBP46, Static/NotControlled/220, Return Gas 35°C, Ambient 35°C, Subcooling 8.3K. Data in accordance to EN 12900:2013 and AHRI 540:2015 polynomial equation and uncertainty guidance.

Operating Envelope

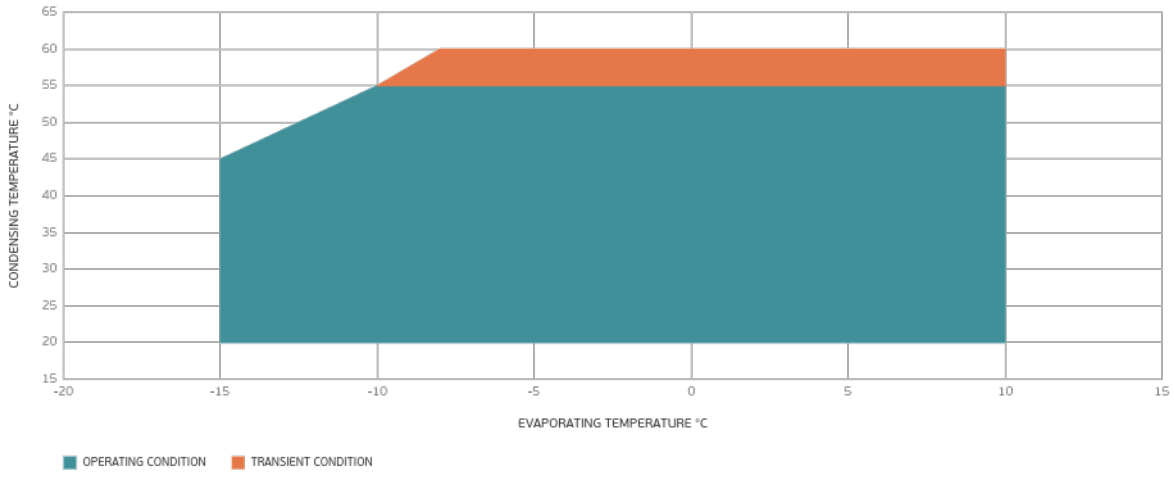

External Dimensions

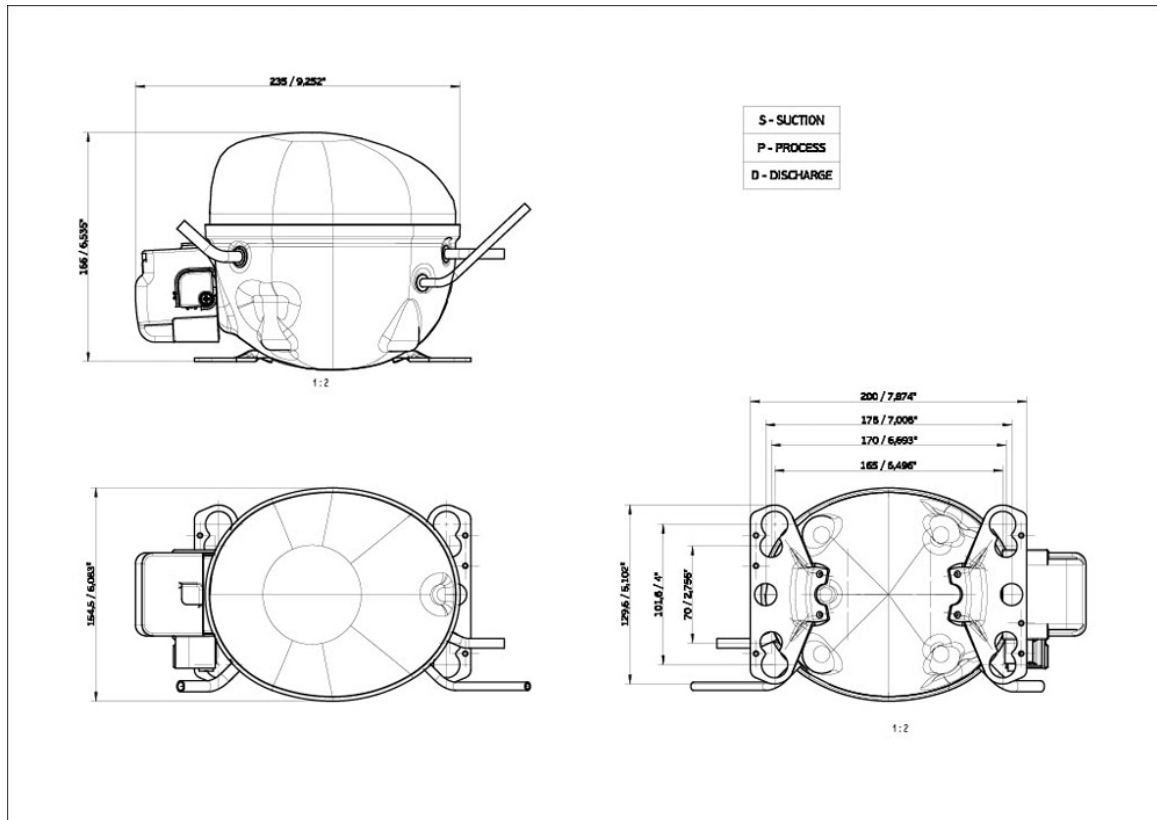

Wiring Diagram

SM28-4

