

GS34MFX

Standard Compressor

R134a

220-240V 50Hz

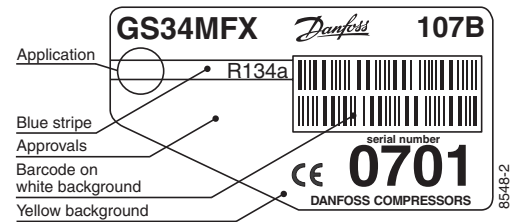

General

Code number	107B0701
Approvals	EN 60335-2-34
Compressors on pallet	48

Application

Application	MBP		
Frequency	Hz	50	60
Evaporating temperature	°C	-20 to 7.2	-
Voltage range	V	198 - 254	-
Max. condensing temperature continuous (short)	°C	60 (70)	-
Max. winding temperature continuous (short)	°C	125 (135)	-

Cooling requirements

Frequency	Hz	50			60		
Application		LBP	MBP	HBP	LBP	MBP	HBP
32°C		-	F ₂	-	-	-	-
38°C		-	F ₂	-	-	-	-
43°C		-	F ₂	-	-	-	-
Remarks on application:							

- S = Static cooling normally sufficient
- O = Oil cooling
- F₁ = Fan cooling 1.5 m/s
(compressor compartment temperature equal to ambient temperature)
- F₂ = Fan cooling 3.0 m/s necessary
- SG = Suction gas cooling normally sufficient
- = not applicable in this area

Design

Displacement	cm ³	33.80
Oil quantity (type)	cm ³	900 (polyolester)
Maximum refrigerant charge	g	2000
Free gas volume in compressor	cm ³	3350
Weight without electrical equipment	kg	20.0

Motor

Motor type	CSR		
LRA (rated after 4 sec. UL984), HST LST	A	25.7	-
Cut in Current, HST LST	A	25.7	-
Resistance, main start winding (25°C)	Ω	2.9	5.1

Dimensions

Height	A	259
	B	247
	B1	234
	B2	234
Suction connector	location/I.D. mm angle	C 12.9 90°
	material comment	Copper Rubber plug
Process connector	location/I.D. mm angle	D 6.5 90°
	material comment	Copper Rubber plug
Discharge connector	location/I.D. mm angle	E 8.2 19°
	material comment	Copper Rubber plug
Oil cooler connector	location/I.D. mm angle	F -
	material comment	-
Connector tolerance	I.D. mm	12.9±0.15, 8.2±0.05, 6.5±0.10
Remarks:		

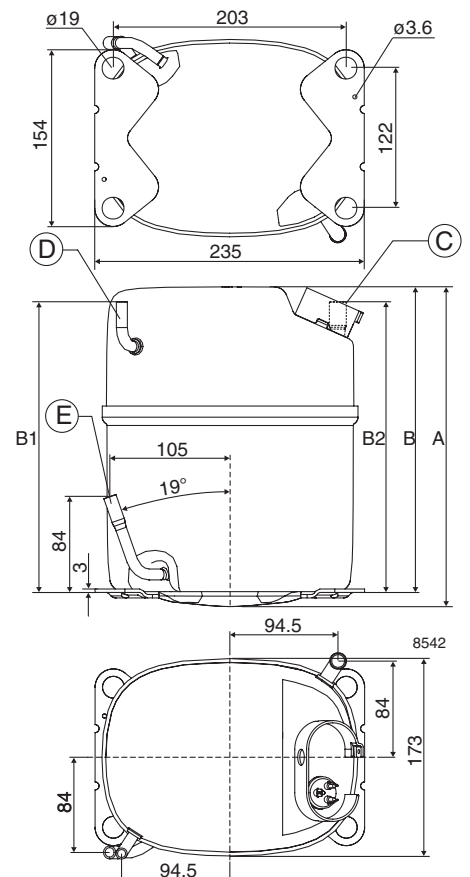

EN 12900

220V, 50Hz, fan cooling F₂

Evap. temp. in °C	-45	-40	-35	-30	-25	-23.3	-20	-15	-10	-6.7	-5	0	5	7.2	10	15	20
Capacity in W							998	1296	1648	1918	2063	2550	3115	3392			
Power cons. in W							722	815	909	974	1008	1115	1234	1291			
Current cons. in A							3.78	4.16	4.59	4.90	5.06	5.58	6.13	6.39			
COP in W/W							1.38	1.59	1.81	1.97	2.05	2.29	2.52	2.63			

ARI 540-99 (MBP)

220V, 50Hz, fan cooling F₂

Evap. temp. in °C	-45	-40	-35	-30	-25	-23.3	-20	-15	-10	-6.7	-5	0	5	7.2	10	15	20
Capacity in W							898	1175	1502	1752	1888	2341					
Power cons. in W							731	833	935	1005	1040	1152					
Current cons. in A							3.81	4.22	4.67	5.00	5.17	5.70					
COP in W/W							1.23	1.41	1.61	1.74	1.82	2.03					

ARI 540-99 (HBP)

220V, 50Hz, fan cooling F₂

Evap. temp. in °C	-45	-40	-35	-30	-25	-23.3	-20	-15	-10	-6.7	-5	0	5	7.2	10	15	20
Capacity in W							822	1088	1401	1640	1769	2200	2703	2952			
Power cons. in W							741	860	975	1053	1092	1213	1342	1402			
Current cons. in A							3.86	4.30	4.78	5.12	5.30	5.87	6.47	6.76			
COP in W/W							1.11	1.27	1.44	1.56	1.62	1.81	2.01	2.11			

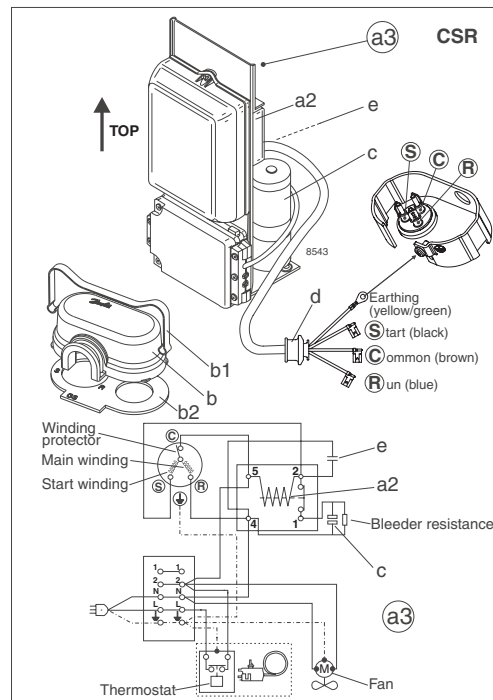

Accessories for GS34MFX	Figure	Code number	Test conditions	EN 12900	ARI 540-99 (MBP)	ARI 540-99 (HBP)
Starting device	a3	117-7056	Condensing temperature	45°C	48.9°C	54.4°C
600 mm cable length			Ambient temperature	32°C	35°C	35°C
			Suction gas temperature	20°C	4.4°C	18.3°C
Cover	b	107B9101 *)	Liquid temperature	no subcooling	no subcooling	no subcooling
Clamp	b1	107B9104 *)				
Gasket	b2	107B9100 *)				
Starting relay	a2	Components of starting device	Mounting accessories	Code number		
Start. capacitor	c		Bolt joint for one comp.	107B9150		
Run capacitor	e		Bolt joint in quantities	-		
*) Remarks: Cover, clamp, gasket parts of compressor			Snap-on in quantities	-		

Danfoss can accept no responsibility for possible errors in catalogues, brochures and other printed material. Danfoss reserves the right to alter its products without notice. This also applies to products already on order provided that such alterations can be made without subsequential changes being necessary in specifications already agreed. All trademarks in this material are property of the respective companies. Danfoss and the Danfoss logotype are trademarks of Danfoss A/S. All rights reserved.