



APPROVALS



ENGINEERING CODE
513306249

APPROVED REFRIGERANT
R-290

POWER SUPPLY
220-240 V 50 Hz

STANDARD CONDITIONS
ASHRAE

APPLICATION
MBP

COOLING CAPACITY
511 W (MBP)

EFFICIENCY
1.82 W/W (MBP)

MOTOR TYPE
CSIR

STARTING TORQUE
HST

DATA

General Data

Type	Hermetic reciprocating
Technology Type	On-Off
Displacement	5.96 cm ³
Compressor Cooling	Fan/NotControlled/220
Expansion Device	Capillary Tube or Expansion Valve
Horse Power	1/3 hp
Power Supply	220-240 V 50 Hz
Evaporating Temperature Range	-20 °C to 10 °C

Electrical Data

Motor type	CSIR
Starting Torque	HST
Start Winding Resistance	18.99 Ω at 25° C
Run Winding Resistance	9.92 Ω at 25° C
Rated Load Amperage (RLA) at 50 Hz	1.35 A

Mechanical Data

Oil Charge	180 ml
Oil Type Configuration	ESTER
Oil Type Viscosity	ISO22
Weight	7.75 Kg

Electrical Components

	Description
Starting Device	Relay MTRPH-0025-65*
Motor Protection	T0571/G6
Start Capacitor	64-77 Uf / 320 V

External Characteristics

Tray Holder	Yes	
Connector	Internal Diameter	Shape
Suction	6.1 mm	Slanted 42° up + 45° to Back/Copper
Discharge	4.94 mm	Slanted parallel BP+24°to Back/Copper
Process	6.1 mm	Slanted 45° up + 45° to Back/Copper

PERFORMANCE

Rated Points

Condensing Temperature	Evaporating Temperature	Cooling Capacity	Power Consumption	Gas Flow Rate	Efficiency
54.40°C	-6.70°C	511 W	281 W	5.86 kg/h	1.82 W/W

Test Condition: ASHRAEMB46, Fan/NotControlled/220, Return Gas 35°C, Evaporation -6.70°C, Condensing 54.40°C, Ambient 35°C , Liquid 46.1°C, Subcooling 8.3K. Data are an indication of performance based simulation.

Performance Curve Data

Condensing Temperature 35°C

Evaporating Temperature °C	Cooling Capacity W	Power W	Gas Flow Rate kg/h	Efficiency W/W
-20	470	202	4.52	2.32
-15	563	214	5.45	2.64
-10	678	224	6.59	3.03
-5	816	234	7.95	3.49
0	975	242	9.56	4.02
5	1157	251	11.42	4.61
10	1363	259	13.56	5.26

Test Condition: ASHRAEMB46, Fan/NotControlled/220, Return Gas 35°C, Ambient 35°C , Subcooling 8.3K. Data are an indication of performance based simulation.

Condensing Temperature 45°C

Evaporating Temperature °C	Cooling Capacity W	Power W	Gas Flow Rate kg/h	Efficiency W/W
-20	394	215	4.10	1.84
-15	470	231	4.91	2.04
-10	565	247	5.93	2.29
-5	680	262	7.17	2.59
0	814	277	8.64	2.94
5	969	292	10.36	3.32
10	1145	308	12.33	3.72

Test Condition: ASHRAEMB46, Fan/NotControlled/220, Return Gas 35°C, Ambient 35°C , Subcooling 8.3K. Data are an indication of performance based simulation.

Condensing Temperature 55°C

Evaporating Temperature °C	Cooling Capacity W	Power W	Gas Flow Rate kg/h	Efficiency W/W
-20	311	234	3.53	1.33
-15	370	252	4.23	1.47
-10	446	270	5.11	1.65
-5	538	287	6.20	1.87
0	648	305	7.52	2.12
5	776	323	9.07	2.4
10	922	342	10.87	2.69

Test Condition: ASHRAEMB46, Fan/NotControlled/220, Return Gas 35°C, Ambient 35°C , Subcooling 8.3K. Data are an indication of performance based simulation.

Operating Envelope

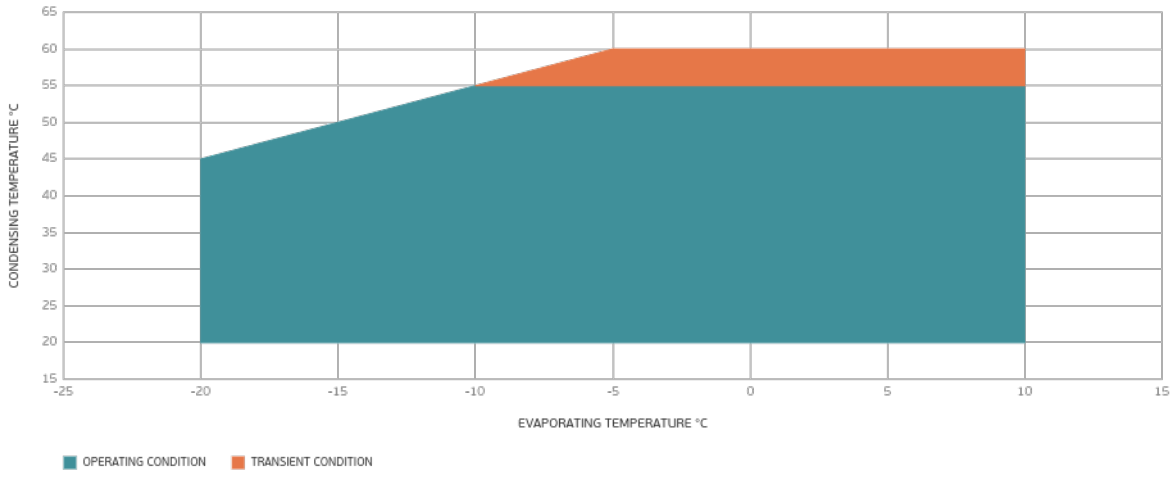

External Dimensions

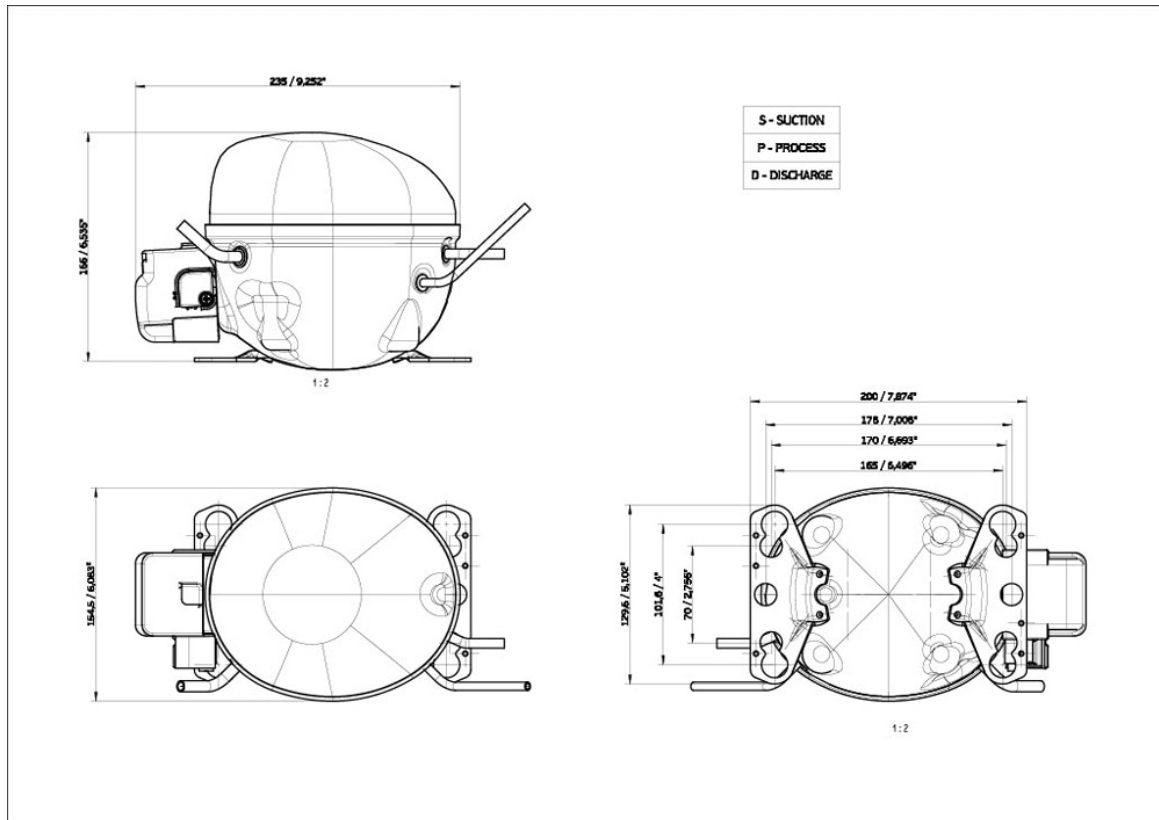

Wiring Diagram

SM28-4

