

APPROVALS



ENGINEERING CODE
843BA02

APPROVED REFRIGERANT
R-290

POWER SUPPLY
220-240 V 50 Hz

STANDARD CONDITIONS
ASHRAE

APPLICATION
LBP

COOLING CAPACITY
1165 W (LBP)

EFFICIENCY
1.38 W/W (LBP)

MOTOR TYPE
CSCR

STARTING TORQUE
HST

DATA

General Data

Type	Hermetic reciprocating
Technology Type	On-Off
Displacement	27.8 cm ³
Compressor Cooling	Fan/NotControlled/220
Fan Air Flow	520 m ³ /h
Expansion Device	Capillary Tube or Expansion Valve
Horse Power	1 1/4 hp
Max Condensing Pressure Operating	18.07 bar
Max Condensing Pressure Peak	20.17 bar
Power Supply	220-240 V 50 Hz
Evaporating Temperature Range	-40 °C to -10 °C

Electrical Data

Motor type	CSCR
Starting Torque	HST
Start Winding Resistance	3.92 Ω at 25° C
Run Winding Resistance	1.72 Ω at 25° C

Mechanical Data

Maximum Recommended Refrigerant Charge	150 g
Oil Charge	450 ml
Oil Type Configuration	ESTER
Oil Type Viscosity	ISO22
Pressurization	Without dry air charge
Weight	18.5 Kg
Free Internal Volume	3.3 L

Electrical Components

	Description
Start Capacitor	88-108 Uf / 330 V
CSR / CSIR Box	YES
Run Capacitor	17.5
Motor Protection	15HM1962-247
Starting Device	RVA2E3C-547

External Characteristics

Base Plate	Universal	
Tray Holder	No	
Height	234 mm	
Connector	Internal Diameter	Shape
Suction	9.6 mm	Vertical/Copper
Discharge	6.42 mm	Vertical/Copper
Process	6.42 mm	Vertical/Copper

PERFORMANCE

Rated Points

Condensing Temperature	Evaporating Temperature	Cooling Capacity	Power Consumption	Current	Gas Flow Rate	Efficiency
54.40°C	-23.30°C	1165 W	843 W	4.42 A	11.83 kg/h	1.38 W/W

Test Condition: ASHRAELBP32, Fan/NotControlled/220, Return Gas 32.2°C, Evaporation -23.30°C, Condensing 54.40°C, Ambient 32.2°C, Liquid 32.2°C, Subcooling 22.2K. Data in accordance to EN

12900:2013 and AHRI 540:2015 polynomial equation and uncertainty guidance.

Performance Curve Data

Condensing Temperature 35°C

Evaporating Temperature °C	Cooling Capacity W	Power W	Current A	Gas Flow Rate kg/h	Efficiency W/W
-40	594	513	3.14	5.98	1.16
-35	772	587	3.4	7.79	1.32
-30	991	663	3.69	10.02	1.49
-25	1253	742	4.01	12.71	1.69
-20	1560	823	4.35	15.88	1.9
-15	1916	908	4.71	19.58	2.11
-10	2323	996	5.09	23.84	2.33

Test Condition: ASHRAELBP32, Fan/NotControlled/220, Return Gas 32.2°C, Ambient 32.2°C, Liquid 32.2°C. Data in accordance to EN 12900:2013 and AHRI 540:2015 polynomial equation and uncertainty guidance.

Condensing Temperature 45°C

Evaporating Temperature °C	Cooling Capacity W	Power W	Current A	Gas Flow Rate kg/h	Efficiency W/W
-35	709	594	3.46	7.15	1.19
-30	917	684	3.79	9.28	1.34
-25	1169	778	4.15	11.86	1.5
-20	1467	875	4.54	14.93	1.68
-15	1812	977	4.96	18.52	1.85
-10	2209	1083	5.41	22.67	2.04

Test Condition: ASHRAELBP32, Fan/NotControlled/220, Return Gas 32.2°C, Ambient 32.2°C, Liquid 32.2°C. Data in accordance to EN 12900:2013 and AHRI 540:2015 polynomial equation and uncertainty guidance.

Condensing Temperature 55°C

Evaporating Temperature °C	Cooling Capacity W	Power W	Current A	Gas Flow Rate kg/h	Efficiency W/W
-30	831	703	3.86	8.40	1.18
-25	1071	807	4.28	10.86	1.33
-20	1357	915	4.73	13.80	1.48
-15	1690	1029	5.21	17.27	1.64
-10	2075	1149	5.73	21.29	1.81

Test Condition: ASHRAELBP32, Fan/NotControlled/220, Return Gas 32.2°C, Ambient 32.2°C, Liquid 32.2°C. Data in accordance to EN 12900:2013 and AHRI 540:2015 polynomial equation and uncertainty guidance.

Operating Envelope

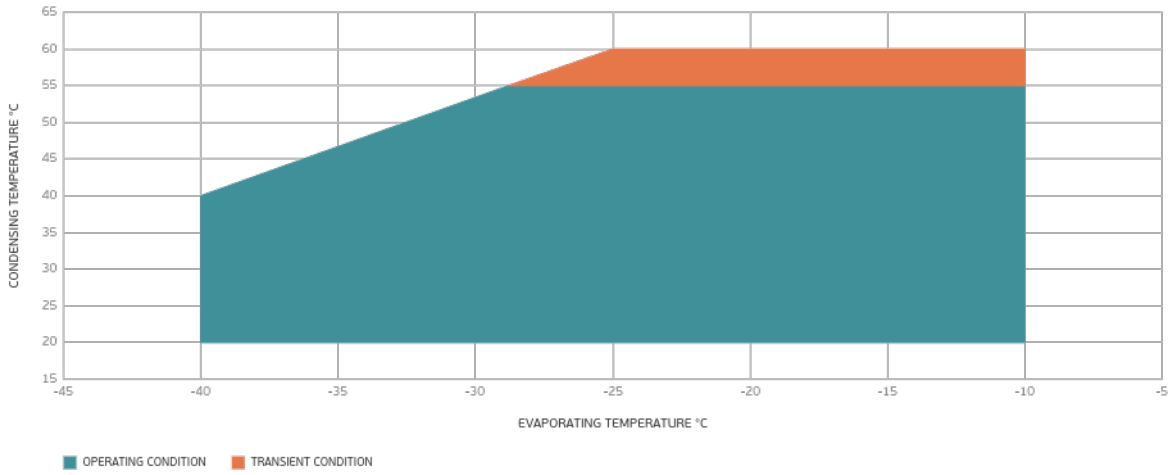

External Dimensions

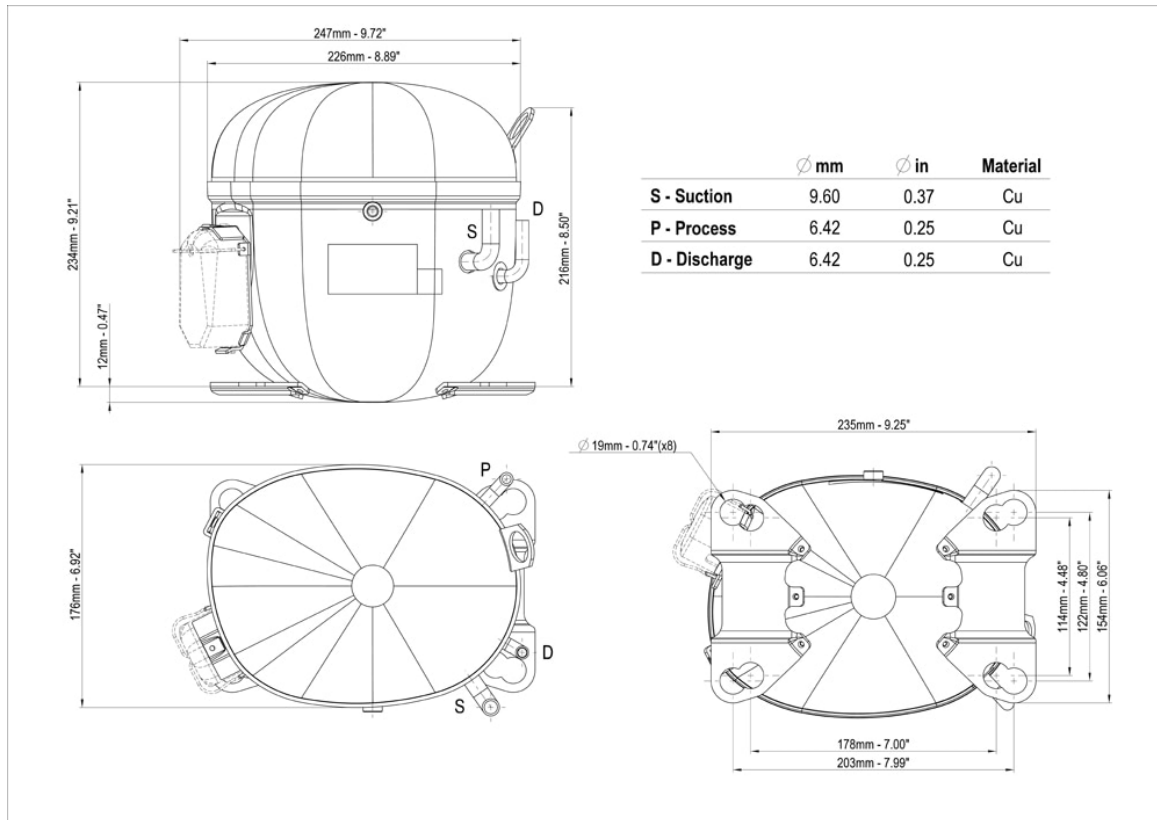

Wiring Diagram

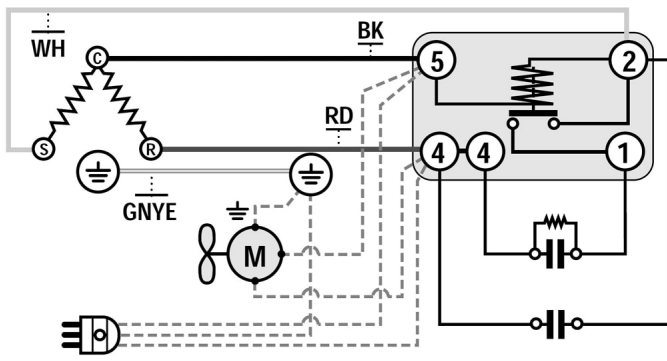

Assembly Instructions

