

# TLES5.7FT.3

## Energy-optimized Tropical Compressor

### R134a

### 220-240V 50Hz

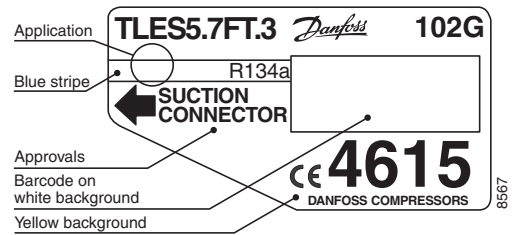

#### General

Code number	102G4615
Approvals	EN 60335-2-34
Compressors on pallet	125

#### Application

Application	LBP		
Frequency	Hz	50	60
Evaporating temperature	°C	-35 to -10	-
Voltage range	V	187 - 254	-
Max. condensing temperature continuous (short)	°C	60 (70)	-
Max. winding temperature continuous (short)	°C	125 (135)	-

#### Cooling requirements

Frequency	Hz	50			60		
Application		LBP	MBP	HBP	LBP	MBP	HBP
32°C		S	-	-	-	-	-
38°C		S	-	-	-	-	-
43°C		S	-	-	-	-	-
Remarks on application:							

- S = Static cooling normally sufficient
- O = Oil cooling
- F<sub>1</sub> = Fan cooling 1.5 m/s (compressor compartment temperature equal to ambient temperature)
- F<sub>2</sub> = Fan cooling 3.0 m/s necessary
- SG = Suction gas cooling normally sufficient
- = not applicable in this area

#### Motor

Motor type	RSIR/RSCR/CSIR		
LRA (rated after 4 sec. UL984), HST   LST	A	5.9	5.5
Cut in Current, HST   LST	A	5.9	10.1
Resistance, main   start winding (25°C)	Ω	13.2	14.8

#### Design

Displacement	cm <sup>3</sup>	5.70
Oil quantity (type)	cm <sup>3</sup>	180 (polyolester)
Maximum refrigerant charge	g	400
Free gas volume in compressor	cm <sup>3</sup>	1790
Weight without electrical equipment	kg	7.5

#### Dimensions

Height	mm	A	173
		B	169
		B1	-
		B2	-
Suction connector	location/I.D. mm   angle	C	6.2   30°
	material   comment		Cu-plated steel   Al caps
Process connector	location/I.D. mm   angle	D	6.2   31.5°
	material   comment		Cu-plated steel   Al caps
Discharge connector	location/I.D. mm   angle	E	5.0   28°
	material   comment		Cu-plated steel   Al caps
Oil cooler connector	location/I.D. mm   angle	F	-
	material   comment		-
Connector tolerance	I.D. mm		±0.09, on 5.0 +0.12/+0.20
Remarks:			

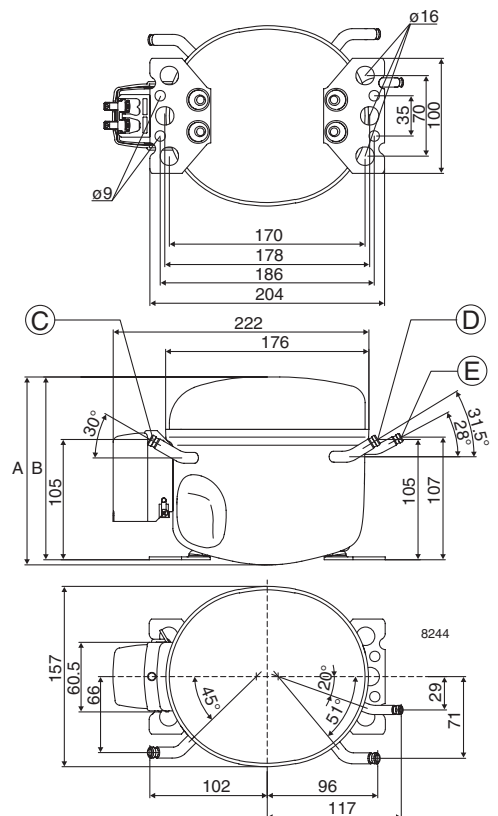

**EN 12900 Household (CECOMAF)** 220V, 50Hz, 2 W PTC consumption incl., static cooling

Evap. temp. in °C	-45	-40	-35	-30	-25	-23.3	-20	-15	-10	-6.7	-5	0	5	7.2	10	15	20
Capacity in W			66.3	90.3	120	132	156	200	253								
Power cons. in W			90.0	105	120	125	136	152	170								
Current cons. in A			0.89	0.92	0.96	0.97	1.00	1.06	1.13								
COP in W/W			0.74	0.86	1.00	1.05	1.15	1.32	1.48								

**EN 12900 Household (CECOMAF)** 220V, 50Hz, RC 4µF, 2 W PTC consumption incl., static cooling

Evap. temp. in °C	-45	-40	-35	-30	-25	-23.3	-20	-15	-10	-6.7	-5	0	5	7.2	10	15	20
Capacity in W			66.3	90.3	120	132	156	200	253								
Power cons. in W			87.6	101	115	120	130	146	163								
Current cons. in A			0.61	0.65	0.70	0.71	0.75	0.82	0.89								
COP in W/W			0.76	0.89	1.04	1.09	1.20	1.37	1.55								

**ASHRAE LBP** 220V, 50Hz, 2 W PTC consumption incl., static cooling

Evap. temp. in °C	-45	-40	-35	-30	-25	-23.3	-20	-15	-10	-6.7	-5	0	5	7.2	10	15	20
Capacity in W			82.3	112	149	163	194	248	314								
Power cons. in W			90.1	105	120	125	135	152	170								
Current cons. in A			0.89	0.92	0.96	0.97	1.00	1.06	1.12								
COP in W/W			0.91	1.07	1.24	1.31	1.43	1.64	1.85								

**ASHRAE LBP** 220V, 50Hz, RC 4µF, 2 W PTC consumption incl., static cooling

Evap. temp. in °C	-45	-40	-35	-30	-25	-23.3	-20	-15	-10	-6.7	-5	0	5	7.2	10	15	20
Capacity in W			82.3	112	149	163	194	248	314								
Power cons. in W			87.8	101	115	120	130	145	162								
Current cons. in A			0.61	0.65	0.69	0.71	0.75	0.81	0.89								
COP in W/W			0.94	1.10	1.29	1.36	1.49	1.71	1.94								

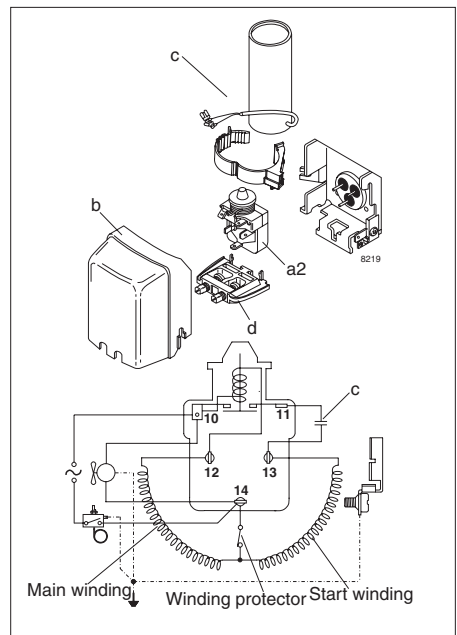
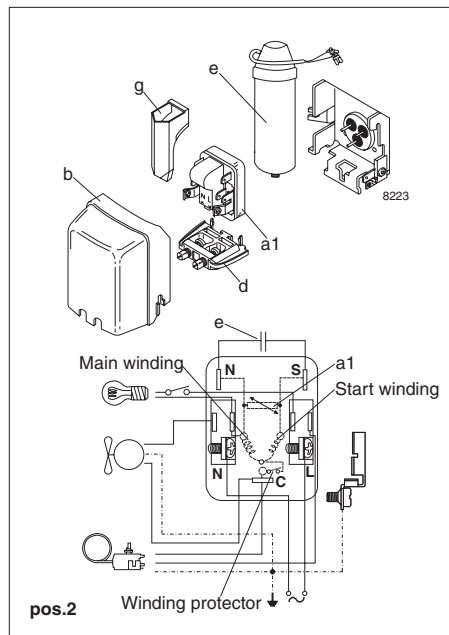
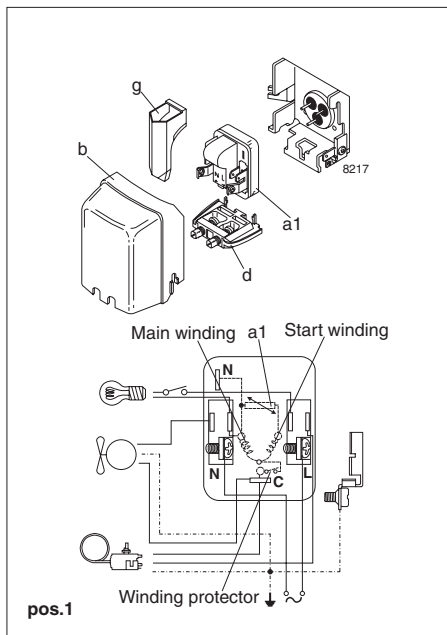

Accessories for	TLES5.7FT.3	Figure	Code number
PTC starting device	6.3 mm spade connectors	a1	103N0011
	4.8 mm spade connectors	(pos.1)	103N0018
PTC starting device	6.3 mm spade connectors	a1	103N0016
	4.8 mm spade connectors	(pos.2)	103N0021
Starting relay	6.3 mm spade connectors	a2	117U6004
Start. capacitor 60 µF	6.3 mm spade connectors	c	117U5014
Cover		b	103N2010
Cord relief		d	103N1010
Run capacitor 4 µF (optional)	6.3 mm spade connectors	e	117-7117
	4.8 mm spade connectors		117-7119
Protection screen for PTC		g	103N0476

Test conditions	EN 12900/CECOMAF	ASHRAE
Condensing temperature	55°C	54.4°C
Ambient temperature	32°C	32°C
Suction gas temperature	32°C	32°C
Liquid temperature	no subcooling	32°C

Mounting accessories	Code number	
Bolt joint for one compressor	Ø: 16 mm	118-1917
Bolt joint in quantities	Ø: 16 mm	118-1918
Snap-on in quantities	Ø: 16 mm	118-1919

Danfoss can accept no responsibility for possible errors in catalogues, brochures and other printed material. Danfoss reserves the right to alter its products without notice. This also applies to products already on order provided that such alterations can be made without subsequential changes being necessary in specifications already agreed. All trademarks in this material are property of the respective companies. Danfoss and the Danfoss logotype are trademarks of Danfoss A/S. All rights reserved.