



APPROVALS



ENGINEERING CODE
513306231

APPROVED REFRIGERANT
R-290

POWER SUPPLY
220-240 V 50 Hz

STANDARD CONDITIONS
ASHRAE

APPLICATION
LBP

COOLING CAPACITY
335 W (LBP)

EFFICIENCY
1.41 W/W (LBP)

MOTOR TYPE
CSIR

STARTING TORQUE
HST

DATA

General Data

Type	Hermetic reciprocating
Technology Type	On-Off
Displacement	6.76 cm ³
Compressor Cooling	Fan/NotControlled/220
Expansion Device	Capillary Tube or Expansion Valve
Horse Power	1/2 hp
Power Supply	220-240 V 50 Hz
Evaporating Temperature Range	-40 °C to -10 °C

Electrical Data

Motor type	CSIR
Starting Torque	HST
Start Winding Resistance	16.95 Ω at 25° C
Run Winding Resistance	10.1 Ω at 25° C
Rated Load Amperage (RLA) at 50 Hz	1.35 A

Mechanical Data

Oil Charge	180 ml
Oil Type Configuration	ESTER
Oil Type Viscosity	ISO22
Weight	8 Kg

Electrical Components

	Description
Starting Device	Relay MTRPH-0025-65*
Motor Protection	T0933/G6
Start Capacitor	72-88 Uf / 330 V

External Characteristics

Tray Holder	No	
Connector	Internal Diameter	Shape
Suction	6.1 mm	Slanted 42° up + 45° to Back/Copper
Discharge	4.94 mm	Slanted parallel BP+24° to Back/Copper
Process	6.1 mm	Slanted 45° up + 45° to Back/Copper

PERFORMANCE

Rated Points

Condensing Temperature	Evaporating Temperature	Cooling Capacity	Power Consumption	Current	Gas Flow Rate	Efficiency
54.40°C	-23.30°C	335 W	237 W	1.64 A	3.40 kg/h	1.41 W/W

Test Condition: ASHRAELBP32, Fan/NotControlled/220, Return Gas 32.2°C, Evaporation -23.30°C, Condensing 54.40°C, Ambient 32.2°C, Liquid 32.2°C, Subcooling 22.2K. Data in accordance to EN

12900:2013 and AHRI 540:2015 polynomial equation and uncertainty guidance.

Performance Curve Data

Condensing Temperature 35°C

Evaporating Temperature °C	Cooling Capacity W	Power W	Current A	Gas Flow Rate kg/h	Efficiency W/W
-40	166	155	1.46	1.68	1.08
-35	217	171	1.49	2.19	1.26
-30	276	188	1.52	2.79	1.47
-25	345	204	1.56	3.50	1.69
-20	426	220	1.6	4.33	1.94
-15	518	235	1.65	5.29	2.2
-10	622	249	1.69	6.39	2.5

Test Condition: ASHRAELBP32, Fan/NotControlled/220, Return Gas 32.2°C, Ambient 32.2°C, Liquid 32.2°C. Data in accordance to EN 12900:2013 and AHRI 540:2015 polynomial equation and uncertainty guidance.

Condensing Temperature 45°C

Evaporating Temperature °C	Cooling Capacity W	Power W	Current A	Gas Flow Rate kg/h	Efficiency W/W
-40	153	158	1.45	1.54	0.96
-35	202	178	1.49	2.04	1.13
-30	260	198	1.54	2.63	1.31
-25	328	218	1.59	3.33	1.51
-20	408	239	1.65	4.15	1.71
-15	499	259	1.71	5.10	1.93
-10	604	280	1.78	6.20	2.16

Test Condition: ASHRAELBP32, Fan/NotControlled/220, Return Gas 32.2°C, Ambient 32.2°C, Liquid 32.2°C. Data in accordance to EN 12900:2013 and AHRI 540:2015 polynomial equation and uncertainty guidance.

Condensing Temperature 55°C

Evaporating Temperature °C	Cooling Capacity W	Power W	Current A	Gas Flow Rate kg/h	Efficiency W/W
-40	138	162	1.45	1.39	0.85
-35	186	183	1.5	1.87	1.01
-30	242	205	1.55	2.45	1.18
-25	309	228	1.62	3.14	1.35
-20	388	253	1.69	3.95	1.53
-15	479	278	1.77	4.89	1.72
-10	582	304	1.86	5.97	1.92

Test Condition: ASHRAELBP32, Fan/NotControlled/220, Return Gas 32.2°C, Ambient 32.2°C, Liquid 32.2°C. Data in accordance to EN 12900:2013 and AHRI 540:2015 polynomial equation and uncertainty guidance.

Operating Envelope

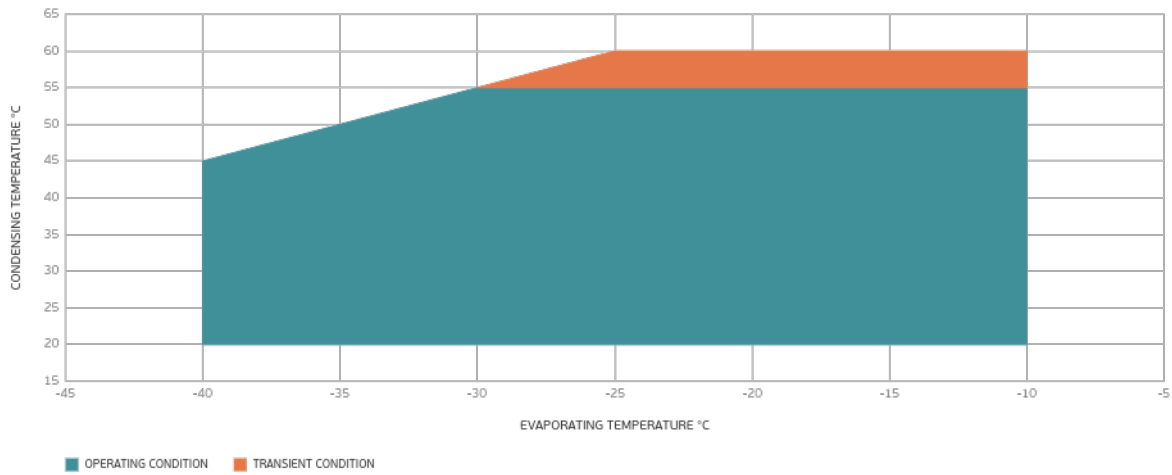

External Dimensions

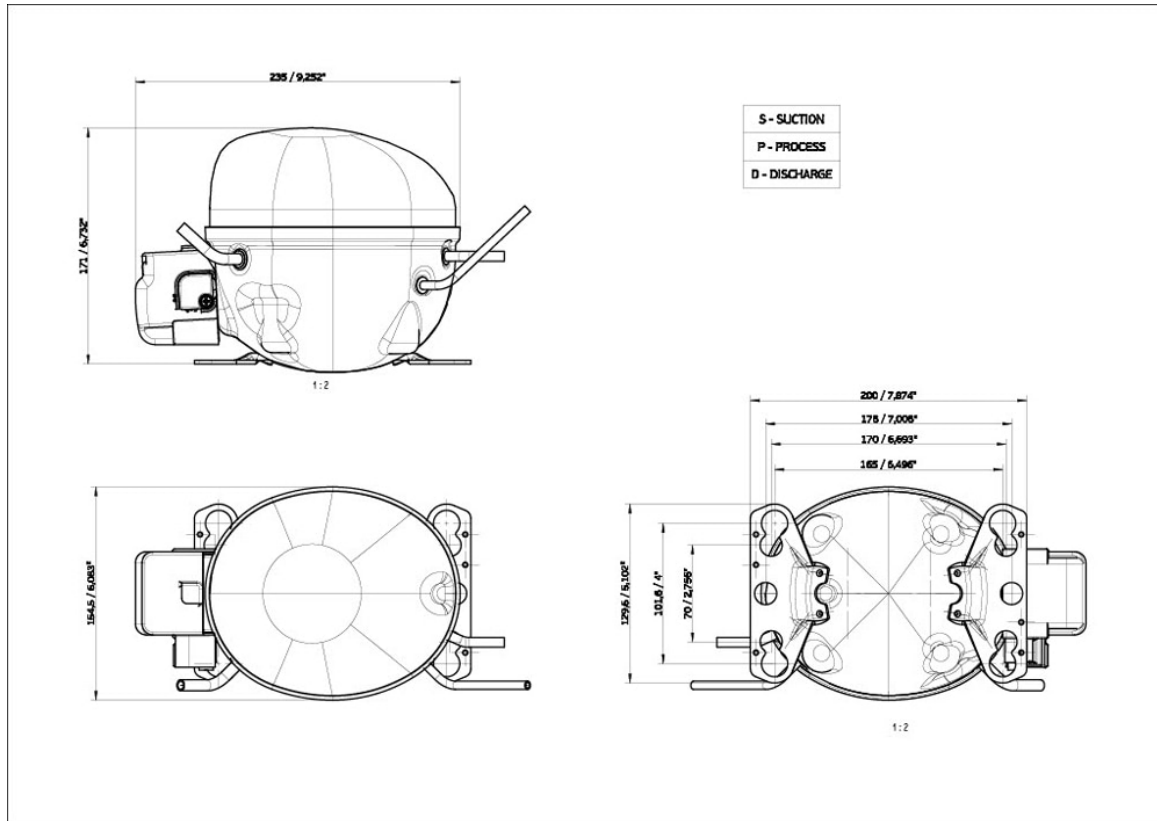

Wiring Diagram

SM28-4

