



APPROVALS



ENGINEERING CODE
913AA62

APPROVED REFRIGERANT
R-404A

POWER SUPPLY
220-240 V 50 Hz

STANDARD CONDITIONS
ASHRAE

APPLICATION
LBP

COOLING CAPACITY
378 W (LBP)

EFFICIENCY
1.29 W/W (LBP)

MOTOR TYPE
CSIR

STARTING TORQUE
HST

DATA

General Data

Type	Hermetic reciprocating
Technology Type	On-Off
Displacement	6.76 cm ³
Compressor Cooling	Fan/NotControlled/220
Expansion Device	Capillary Tube or Expansion Valve
Horse Power	1/2 hp
Power Supply	220-240 V 50 Hz
Evaporating Temperature Range	-40 °C to -10 °C

Electrical Data

Motor type	CSIR
Starting Torque	HST
Start Winding Resistance	17 Ω at 25° C
Run Winding Resistance	10 Ω at 25° C

Mechanical Data

Oil Charge	180 ml
Oil Type Configuration	ESTER
Oil Type Viscosity	ISO22
Weight	8 Kg

Electrical Components

	Description
Start Capacitor	72-88 Uf / 330 V
Motor Protection	T0971/G6
Starting Device	Relay MTRPH-0025-59*

External Characteristics

Tray Holder	No	
Connector	Internal Diameter	Shape
Suction	6.1 mm	Slanted 42°/Copper
Discharge	4.94 mm	Straight/Copper
Process	6.1 mm	Slanted 42°/Copper

PERFORMANCE

Rated Points

Condensing Temperature	Evaporating Temperature	Cooling Capacity	Power Consumption	Current	Gas Flow Rate	Efficiency
54.40°C	-23.30°C	378 W	294 W	1.82 A	8.75 kg/h	1.29 W/W

Test Condition: ASHRAELBP32, Fan/NotControlled/220, Return Gas 32.2°C, Evaporation -23.30°C, Condensing 54.40°C, Ambient 32.2°C, Liquid 32.2°C, Subcooling 22.2K. Data in accordance to EN

12900:2013 and AHRI 540:2015 polynomial equation and uncertainty guidance.

Performance Curve Data

Condensing Temperature 35°C

Evaporating Temperature °C	Cooling Capacity W	Power W	Current A	Gas Flow Rate kg/h	Efficiency W/W
-40	194	180	1.5	4.44	1.07
-35	251	203	1.55	5.78	1.24
-30	321	227	1.62	7.41	1.41
-25	405	254	1.71	9.38	1.6
-20	502	280	1.8	11.71	1.79
-15	615	309	1.9	14.41	1.99
-10	742	338	2	17.52	2.19

Test Condition: ASHRAELBP32, Fan/NotControlled/220, Return Gas 32.2°C, Ambient 32.2°C, Liquid 32.2°C. Data in accordance to EN 12900:2013 and AHRI 540:2015 polynomial equation and uncertainty guidance.

Condensing Temperature 45°C

Evaporating Temperature °C	Cooling Capacity W	Power W	Current A	Gas Flow Rate kg/h	Efficiency W/W
-40	177	183	1.5	4.05	0.97
-35	232	208	1.56	5.32	1.11
-30	299	237	1.64	6.89	1.26
-25	380	268	1.74	8.78	1.41
-20	474	302	1.86	11.02	1.57
-15	583	338	1.98	13.64	1.72
-10	707	377	2.11	16.66	1.88

Test Condition: ASHRAELBP32, Fan/NotControlled/220, Return Gas 32.2°C, Ambient 32.2°C, Liquid 32.2°C. Data in accordance to EN 12900:2013 and AHRI 540:2015 polynomial equation and uncertainty guidance.

Condensing Temperature 55°C

Evaporating Temperature °C	Cooling Capacity W	Power W	Current A	Gas Flow Rate kg/h	Efficiency W/W
-40	155	186	1.5	3.54	0.83
-35	207	214	1.56	4.74	0.97
-30	271	246	1.66	6.23	1.1
-25	348	281	1.78	8.04	1.24
-20	439	320	1.92	10.19	1.37
-15	545	363	2.08	12.71	1.5
-10	665	409	2.25	15.63	1.62

Test Condition: ASHRAELBP32, Fan/NotControlled/220, Return Gas 32.2°C, Ambient 32.2°C, Liquid 32.2°C. Data in accordance to EN 12900:2013 and AHRI 540:2015 polynomial equation and uncertainty guidance.

Operating Envelope

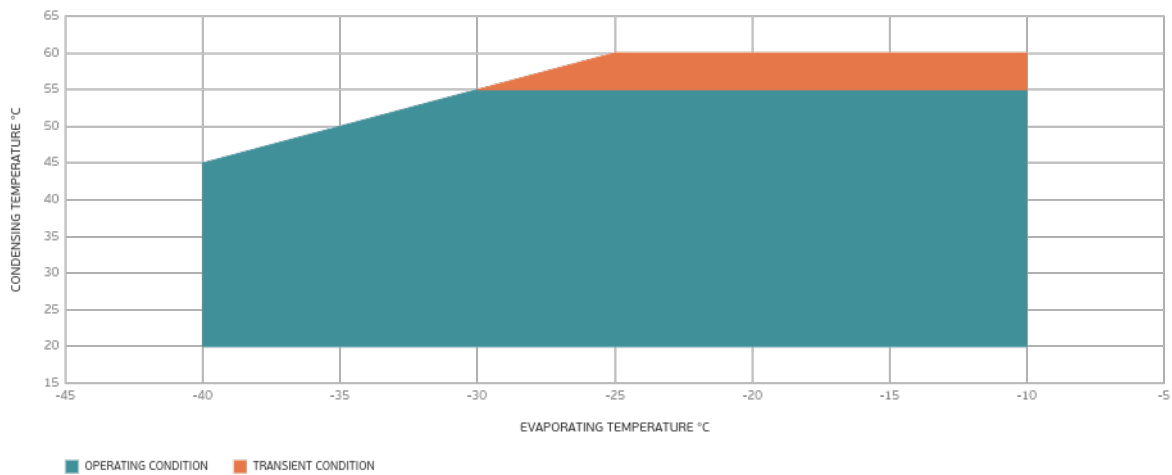

External Dimensions

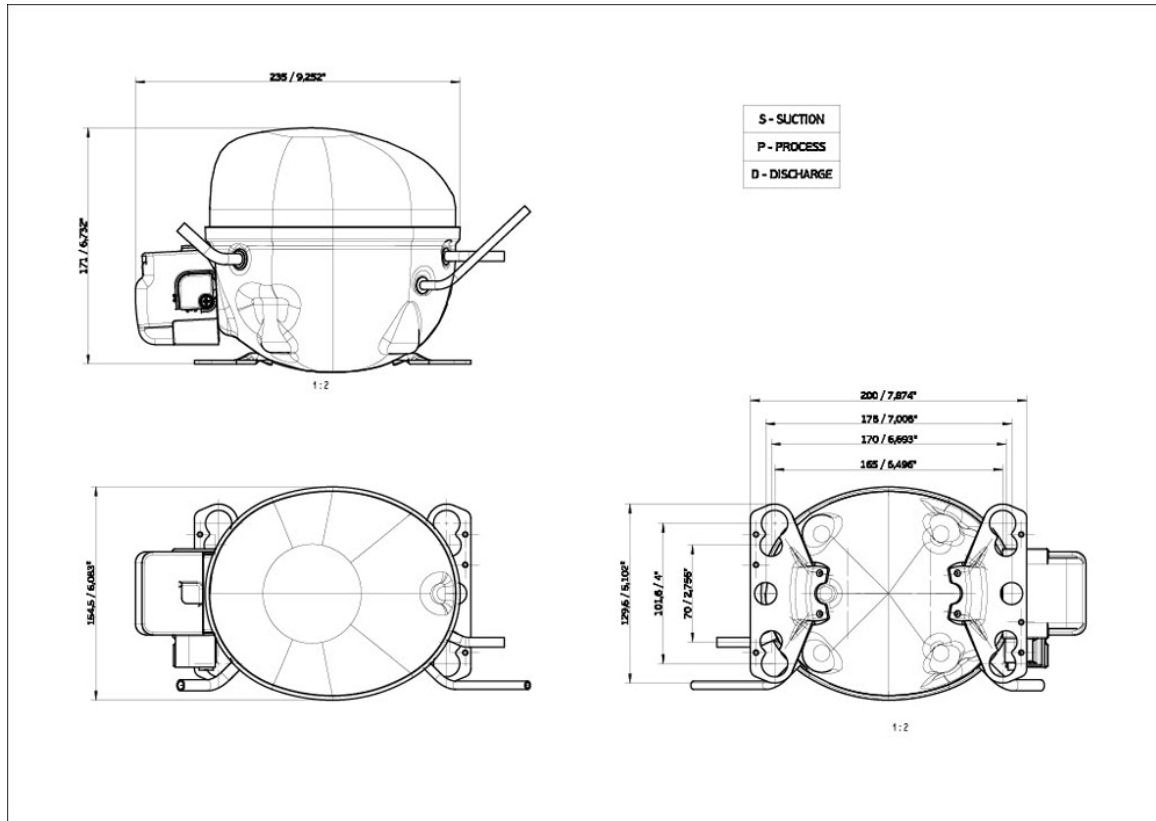

Wiring Diagram

SM28-4

