



APPROVALS



ENGINEERING CODE
923KA02

APPROVED REFRIGERANT
R-404A

POWER SUPPLY
220-240 V 50 Hz

STANDARD CONDITIONS
ASHRAE

APPLICATION
LBP

COOLING CAPACITY
1291 W (LBP)

EFFICIENCY
1.34 W/W (LBP)

MOTOR TYPE
CSCR

STARTING TORQUE
HST

DATA

General Data

Type	Hermetic reciprocating
Technology Type	On-Off
Displacement	26.21 cm ³
Compressor Cooling	Fan/NotControlled/220
Fan Air Flow	520 m ³ /h
Expansion Device	Capillary Tube or Expansion Valve
Horse Power	1 1/4 hp
Max Condensing Pressure Operating	24.71 bar
Max Condensing Pressure Peak	27.71 bar
Power Supply	220-240 V 50 Hz
Evaporating Temperature Range	-40 °C to -10 °C

Electrical Data

Motor type	CSCR
Starting Torque	HST
Start Winding Resistance	3.92 Ω at 25° C
Run Winding Resistance	1.72 Ω at 25° C

Mechanical Data

Maximum Recommended Refrigerant Charge	800 g
Oil Charge	650 ml
Oil Type Configuration	ESTER
Oil Type Viscosity	ISO22
Pressurization	Dry air charge
Weight	17.9 Kg
Free Internal Volume	3.3 L

Electrical Components

	Description
Run Capacitor	20
Start Capacitor	88-108 Uf / 330 V
CSR / CSIR Box	YES
Starting Device	RVA2E3C-103
Motor Protection	15HM1962-247

External Characteristics

Base Plate	Universal	
Tray Holder	No	
Height	234 mm	
Connector	Internal Diameter	Shape
Suction	9.6 mm	Vertical/Copper
Discharge	6.42 mm	Vertical/Copper
Process	6.42 mm	Vertical/Copper

PERFORMANCE

Rated Points

Condensing Temperature	Evaporating Temperature	Cooling Capacity	Power Consumption	Gas Flow Rate	Efficiency
54.40°C	-23.30°C	1291 W	964 W	29.86 kg/h	1.34 W/W

Test Condition: ASHRAELBP32, Fan/NotControlled/220, Return Gas 32.2°C, Evaporation -23.30°C, Condensing 54.40°C, Ambient 32.2°C, Liquid 32.2°C, Subcooling 22.2K. Data are an indication of performance based simulation.

Performance Curve Data

Condensing Temperature 35°C

Evaporating Temperature °C	Cooling Capacity W	Power W	Gas Flow Rate kg/h	Efficiency W/W
-40	575	558	13.18	1.03
-35	780	643	17.96	1.21
-30	1040	731	24.01	1.42
-25	1352	822	31.35	1.65
-20	1715	916	39.96	1.87
-15	2126	1013	49.84	2.1
-10	2583	1114	60.98	2.32

Test Condition: ASHRAELBP32, Fan/NotControlled/220, Return Gas 32.2°C, Ambient 32.2°C, Liquid 32.2°C. Data are an indication of performance based simulation.

Condensing Temperature 45°C

Evaporating Temperature °C	Cooling Capacity W	Power W	Gas Flow Rate kg/h	Efficiency W/W
-35	727	657	16.70	1.11
-30	975	763	22.46	1.28
-25	1275	873	29.50	1.46
-20	1625	986	37.79	1.65
-15	2023	1104	47.34	1.83
-10	2468	1226	58.15	2.01

Test Condition: ASHRAELBP32, Fan/NotControlled/220, Return Gas 32.2°C, Ambient 32.2°C, Liquid 32.2°C. Data are an indication of performance based simulation.

Condensing Temperature 55°C

Evaporating Temperature °C	Cooling Capacity W	Power W	Gas Flow Rate kg/h	Efficiency W/W
-30	895	802	20.59	1.12
-25	1180	923	27.26	1.28
-20	1516	1049	35.18	1.44
-15	1899	1180	44.35	1.61
-10	2329	1316	54.76	1.77

Test Condition: ASHRAELBP32, Fan/NotControlled/220, Return Gas 32.2°C, Ambient 32.2°C, Liquid 32.2°C. Data are an indication of performance based simulation.

Operating Envelope

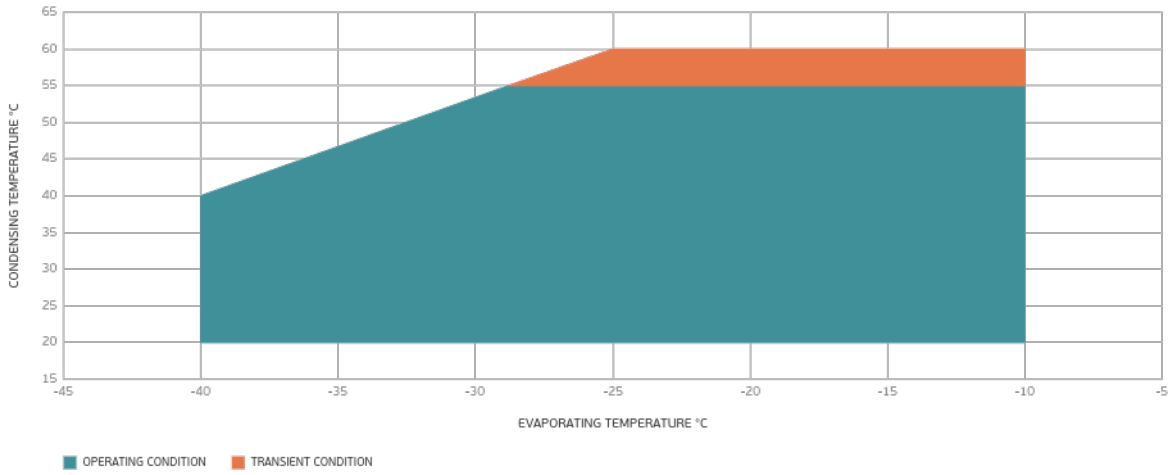

External Dimensions

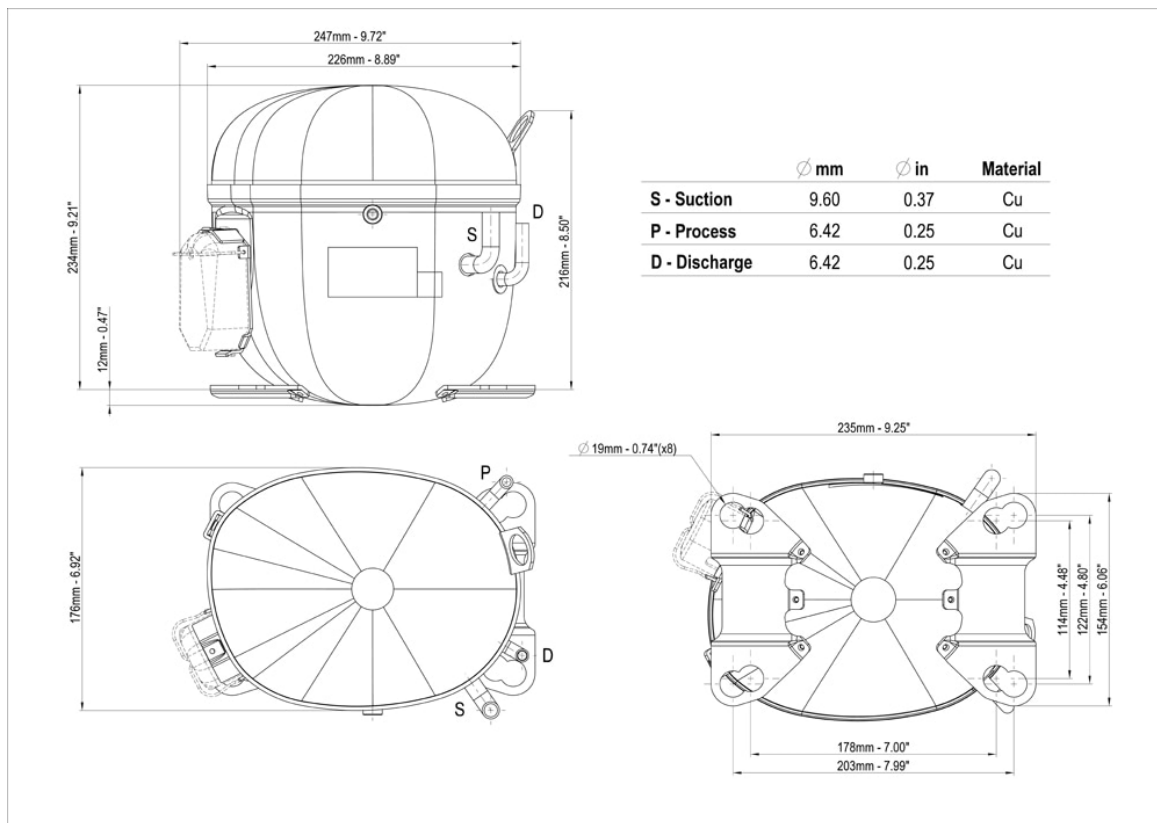

Wiring Diagram

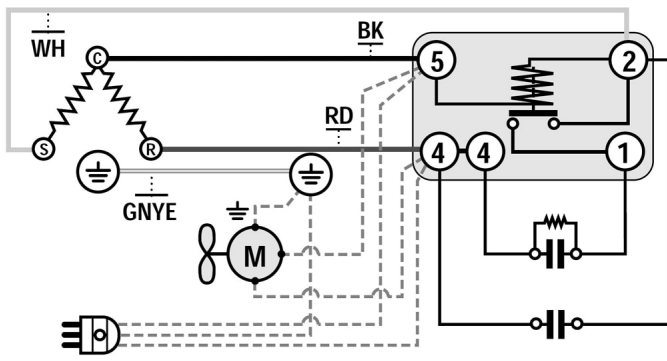

Assembly Instructions

