



APPROVALS



 **ENGINEERING CODE**
861LA51

 **APPROVED REFRIGERANT**
R-600a

 **POWER SUPPLY**
220-240 V 50 Hz

 **STANDARD CONDITIONS**
ASHRAE

 **APPLICATION**
HBP

 **COOLING CAPACITY**
812 W (HBP)

 **EFFICIENCY**
2.49 W/W (HBP)

 **MOTOR TYPE**
CSIR

 **STARTING TORQUE**
HST

DATA

General Data

Type	Hermetic reciprocating
Technology Type	On-Off
Displacement	14.28 cm ³
Compressor Cooling	Fan/NotControlled/220
Fan Air Flow	520 m ³ /h
Expansion Device	Capillary Tube or Expansion Valve
Horse Power	1/4 hp
Max Condensing Pressure Operating	6.73 bar
Max Condensing Pressure Peak	7.69 bar
Power Supply	220-240 V 50 Hz
Evaporating Temperature Range	-15 °C to 10 °C

Electrical Data

Motor type	CSIR
Starting Torque	HST
Start Winding Resistance	28.9 Ω at 25° C
Run Winding Resistance	6.8 Ω at 25° C

Mechanical Data

Maximum Recommended Refrigerant Charge	150 g
Oil Charge	350 ml
Oil Type Configuration	MINERAL
Oil Type Viscosity	ISO32
Pressurization	Without dry air charge
Weight	10.6 Kg
Free Internal Volume	2.1 L

Electrical Components

	Description
Start Capacitor	43-53 Uf / 330 V
Motor Protection	T0186/G6
Starting Device	Relay MTRPH-0026-59*

External Characteristics

Base Plate	European	
Tray Holder	No	
Height	188 mm	
Connector	Internal Diameter	Shape
Suction	8.1 mm	Slanted 42°/Copper
Discharge	6.1 mm	Straight/Copper
Process	6.1 mm	Slanted 42°/Copper

PERFORMANCE

Rated Points

Condensing Temperature	Evaporating Temperature	Cooling Capacity	Power Consumption	Current	Gas Flow Rate	Efficiency
54.40°C	7.20°C	812 W	326 W	2.06 A	9.76 kg/h	2.49 W/W

Test Condition: ASHRAE HBP46, Fan/NotControlled/220, Return Gas 35°C, Evaporation 7.20°C, Condensing 54.40°C, Ambient 35°C, Liquid 46.1°C, Subcooling 8.3K. Data in accordance to EN

12900:2013 and AHRI 540:2015 polynomial equation and uncertainty guidance.

Performance Curve Data

Condensing Temperature 35°C

Evaporating Temperature °C	Cooling Capacity W	Power W	Current A	Gas Flow Rate kg/h	Efficiency W/W
-15	401	196	1.62	4.09	2.04
-10	504	213	1.67	5.16	2.36
-5	624	229	1.72	6.40	2.72
0	762	244	1.77	7.84	3.13
5	919	257	1.82	9.48	3.57
10	1097	270	1.87	11.35	4.06

Test Condition: ASHRAEHBP46, Fan/NotControlled/220, Return Gas 35°C, Ambient 35°C, Subcooling 8.3K. Data in accordance to EN 12900:2013 and AHRI 540:2015 polynomial equation and uncertainty guidance.

Condensing Temperature 45°C

Evaporating Temperature °C	Cooling Capacity W	Power W	Current A	Gas Flow Rate kg/h	Efficiency W/W
-15	355	205	1.64	3.90	1.73
-10	449	227	1.71	4.94	1.98
-5	559	248	1.78	6.17	2.25
0	687	269	1.85	7.60	2.55
5	832	289	1.92	9.24	2.88
10	996	309	1.99	11.10	3.23

Test Condition: ASHRAEHBP46, Fan/NotControlled/220, Return Gas 35°C, Ambient 35°C, Subcooling 8.3K. Data in accordance to EN 12900:2013 and AHRI 540:2015 polynomial equation and uncertainty guidance.

Condensing Temperature 55°C

Evaporating Temperature °C	Cooling Capacity W	Power W	Current A	Gas Flow Rate kg/h	Efficiency W/W
-10	396	241	1.75	4.73	1.64
-5	495	266	1.84	5.93	1.86
0	611	291	1.93	7.34	2.1
5	744	315	2.02	8.96	2.36
10	894	340	2.12	10.82	2.63

Test Condition: ASHRAEHBP46, Fan/NotControlled/220, Return Gas 35°C, Ambient 35°C, Subcooling 8.3K. Data in accordance to EN 12900:2013 and AHRI 540:2015 polynomial equation and uncertainty guidance.

Operating Envelope

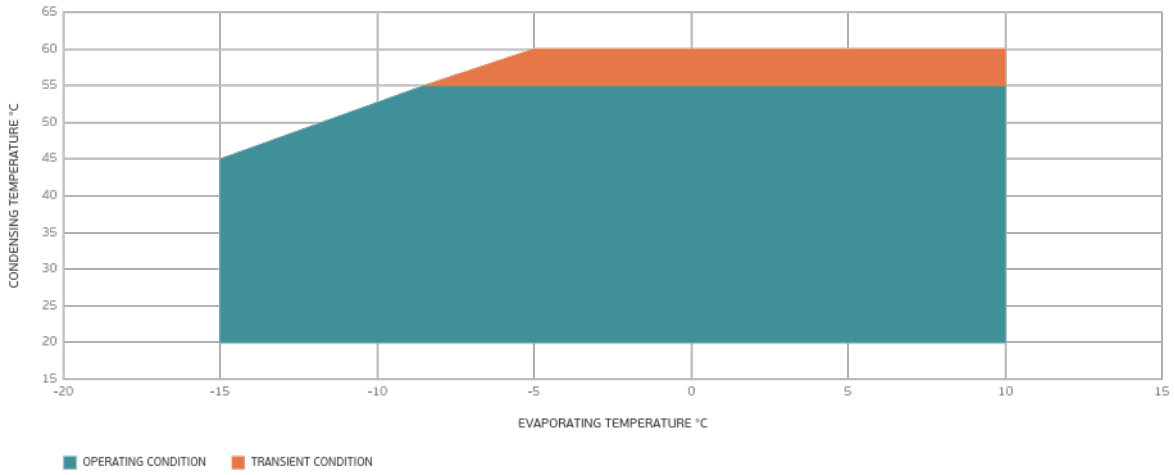

External Dimensions

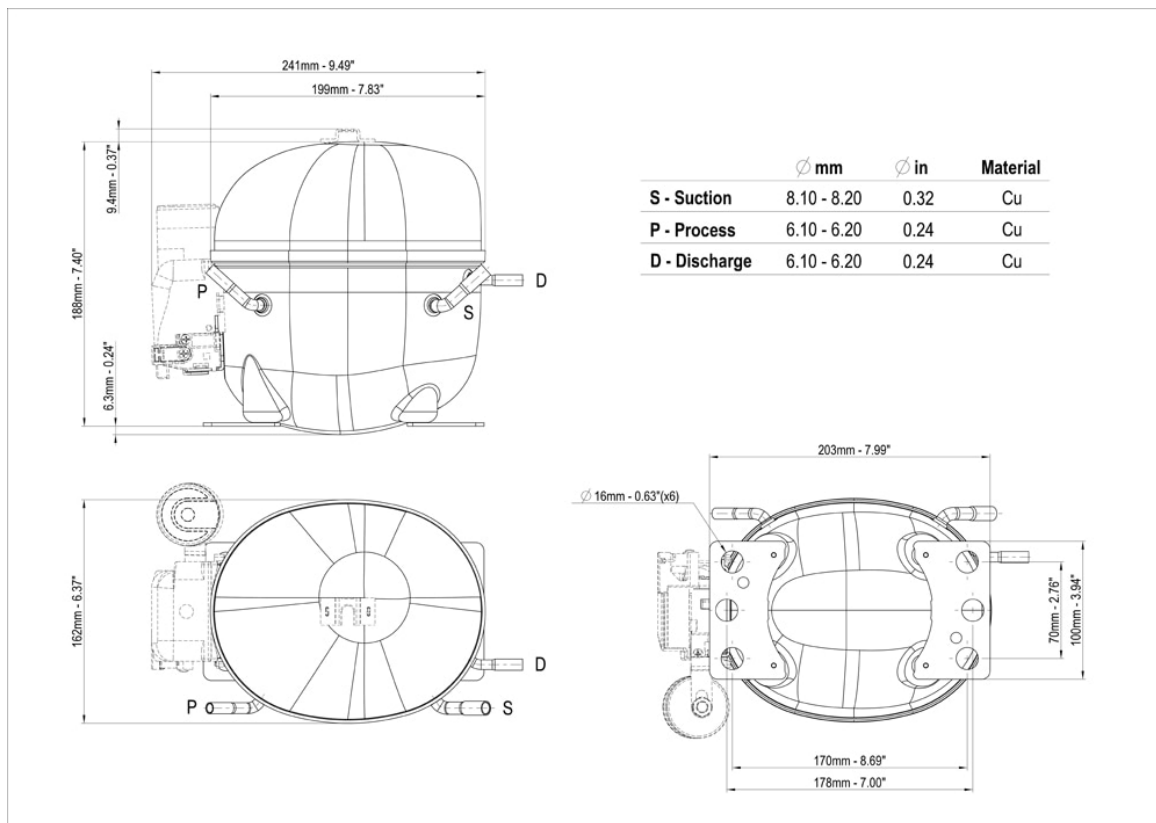

Wiring Diagram

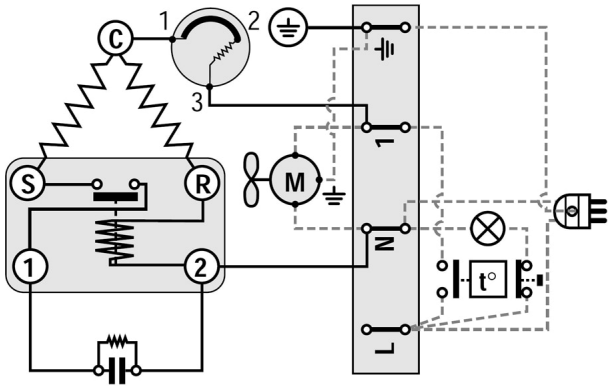

Assembly Instructions

