

压缩机特性规格书

PERFORMANCE FOR COMPRESSOR

机型 (MODEL): QDZH50G

12/24V (DC)

1、适用范围 (APPLICATION)

蒸发温度范围 (EVAPORATING TEMP RANGE)	-35~-15℃
冷却方式 (COOLING TYPE)	风冷 (F)
制冷控制 (REFRIGERATION CONTROL)	毛细管 (CAPILLARY)
认证种类 (APPROVAL)	CE
电压范围 (VOLTAGE RANGE)	12/24 (DC)
冷媒 (REFRIGERANT)	R134a

2、额定性能及测试条件 (RATED PERFORMANCE AND TEST CONDITIONS)

转速 ROTATE SPEED	制冷量 COOLING CAPACITY	能效比 EFFICIENCY: COP
2000 (rpm)	87.0 (W)	1.17 (W/W)
2500 (rpm)	104.0 (W)	1.13 (W/W)
3000 (rpm)	130.0 (W)	1.35 (W/W)
3500 (rpm)	163.0 (W)	1.2 (W/W)
测试工况 (ASHRAE TEST CONDITION)	低背压 (LBP)	
测试电源 (TEST POWER SOURCE)	12/24 (DC)	
蒸发温度 (EVAPORATING TEMP)	-23.3℃	
冷凝温度 (CONDENSING TEMP)	54.4℃	
吸气温度 (SUNCTION TEMP)	32.2℃	
过冷温度 (SUBCOOLING TEMP)	32.2℃	
环境温度 (AMBIENT TEMP)	32.2℃	

压缩机特性规格书

PERFORMANCE FOR COMPRESSOR

机型 (MODEL): QDZH50G

12/24V (DC)

3、主要构造项目 (MAIN STRUCTURE)

压缩机类型 (COMPRESSOR TYPE)	全封闭型电动压缩机 (HERMTIC MOTOR-COMPRESSOR)
泵体类型 (PUMP TYPE)	往复式 (RECIPROCATING TYPE)
冷冻机油类型(OIL TYPE)	酯类油 RL22H
冷冻机油充注量(OIL CHARGE)	180ml
涂装(PAINTING)	黑色涂装, 烘烤干燥 (BLACK PAINT,BAKED)
净重(NET WEIGHT)	4.9Kg
吸气管内径(ID OF SUCTION TUBE)	Ø6.2±0.1
排气管内径(ID OF DISCHARGE TUBE)	Ø5.1±0.1
工艺管内径(ID OF PROCESS TUBE)	Ø6.2±0.1
残余杂质 (RESIDUAL IMPURITIES)	80mg MAX
残余水分 (RESIDUAL MOISTURE)	100mg MAX

4、电机 (MOTOR)

启动方式 (STARTING TYPE)	MK-75-12/24
电压范围 (VOLTAGE RANGE)	12/24V
绝缘等级 (INSULATION GRADE)	B GRADE

压缩机特性规格书

PERFORMANCE FOR COMPRESSOR

机型 (MODEL): QDZH50G

12/24V (DC)

5、电器元件 (ELECTRICAL COMPONENTS)

压缩机转速 MOTOR SPEED	C/T(8)间电阻 RESISTANCE(8)	C/T(间)电流 C/T CURRENT
2000 (rpm)	0 (Ω)	0.87~1.02 (mA)
2100 (rpm)	51 (Ω)	1.02~1.17 (mA)
2200 (rpm)	100 (Ω)	1.17~1.32 (mA)
2300 (rpm)	150 (Ω)	1.32~1.48 (mA)
2400 (rpm)	200 (Ω)	1.48~1.63 (mA)
2500 (rpm)	277 (Ω)	1.63~1.78 (mA)
2600 (rpm)	330 (Ω)	1.78~1.93 (mA)
2700 (rpm)	400 (Ω)	1.93~2.08 (mA)
2800 (rpm)	490 (Ω)	2.08~2.24 (mA)
2900 (rpm)	586 (Ω)	2.24~2.39 (mA)
3000 (rpm)	692 (Ω)	2.39~2.54 (mA)
3100 (rpm)	816 (Ω)	2.54~2.69 (mA)
3200 (rpm)	963 (Ω)	2.69~2.84 (mA)
3300 (rpm)	1137 (Ω)	2.84~3.00 (mA)
3400 (rpm)	1331 (Ω)	3.00~3.15 (mA)
3500 (rpm)	1523 (Ω)	3.15~3.61 (mA)
STOP	>3000 (Ω)	3.61~5.00 (mA)

压缩机规格书及附件清单

LIST OF COMPRESSOR & ACCESSORIES

机型 (MODEL): QDZH50G

12/24V (DC)

6、附件清单 (ACCESSORIES LIST)

名称 (NAME)	规格 (DESCRIPTION)	数量 (QTY)
控制器 (CONTROLLER)	MK-75-12/24 MK-QDZH75G	1
减震胶座 (RUBBER GROMMET)		4
安装套管 (BUSHING)		4

7、接线方式 (ELECTRICAL WIRING DIAGRAM)

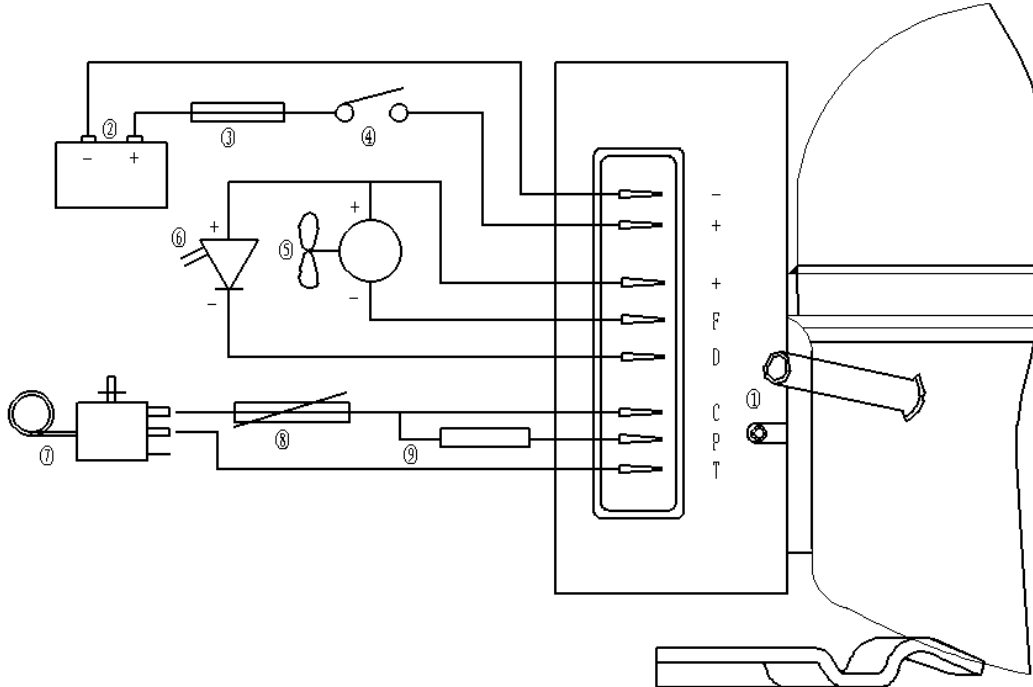

压缩机外形尺寸图

DIMENSIONS FOR COMPRESSOR

机型 (MODEL): QDZH50G

12/24V (DC)

8、压缩机外形图 (DIMENSIONS FOR COMPRESSOR) :

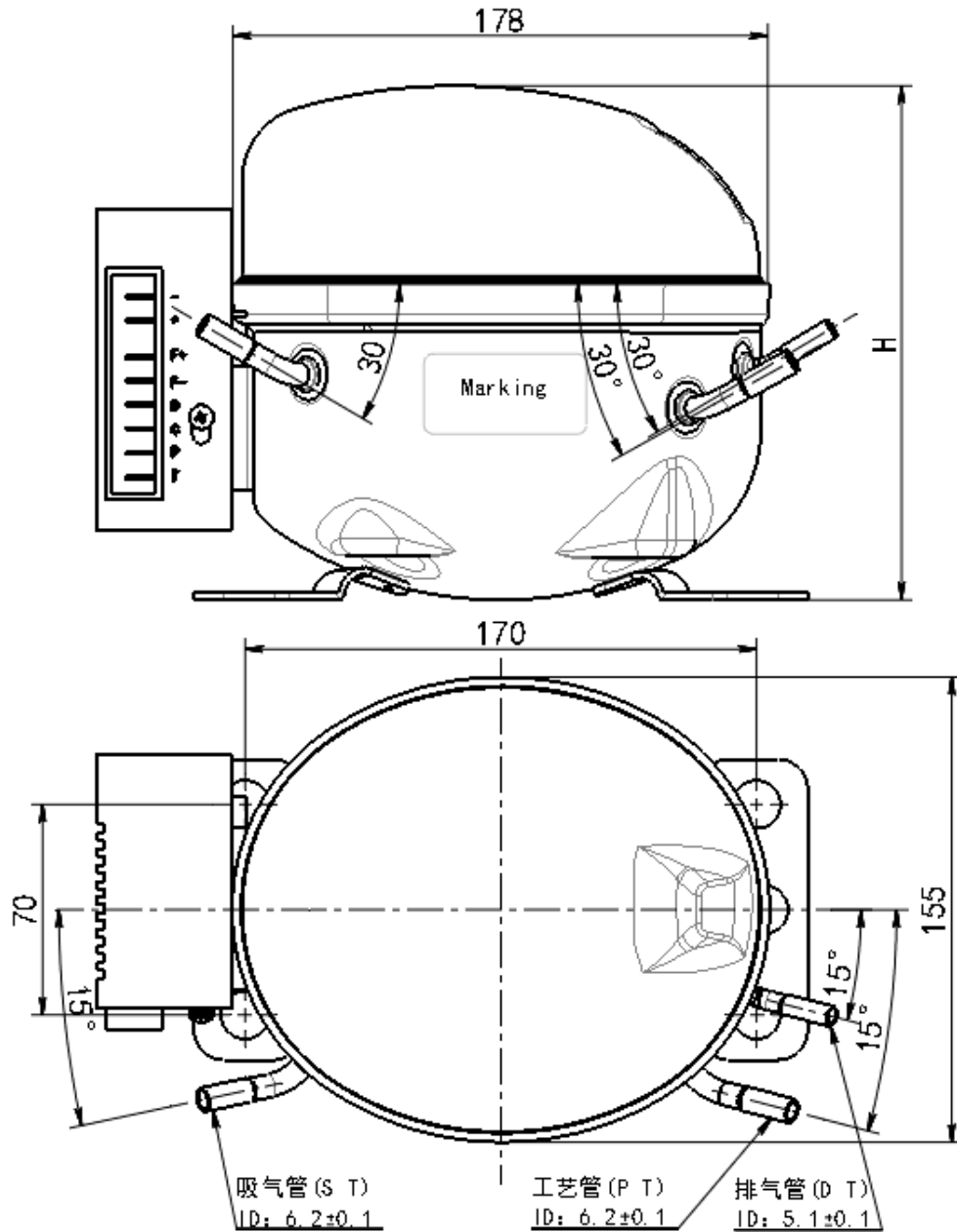

压缩机高度 Height value of compressor: $H=174.5 \pm 2\text{mm}$.

压缩机安装示意图

MOUNTING DIAGRAM FOR COMPRESSOR

机型 (MODEL): QDZH50G

12/24V (DC)

9、安装图 (MOUNTING DIAGRAM FOR COMPRESSOR)

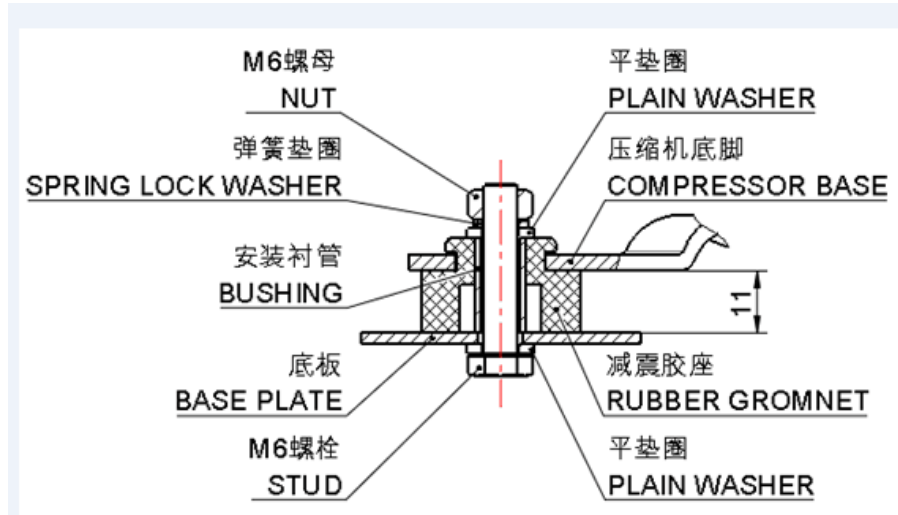

安装方式 (MOUNTING TYPE) :(1)

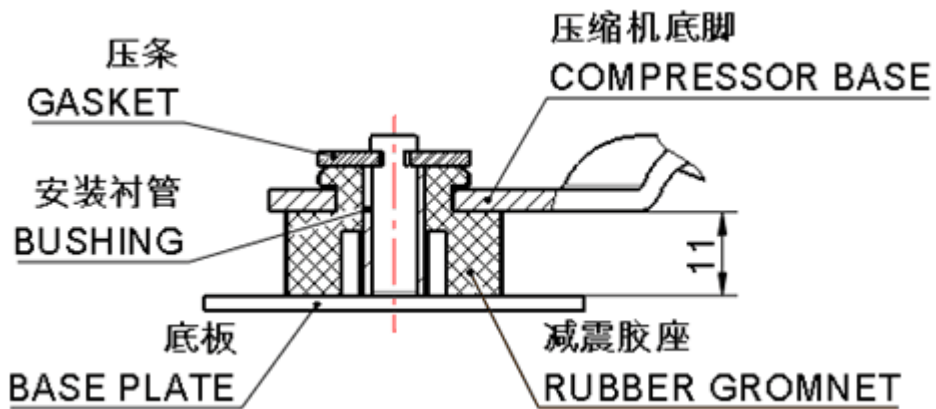

安装方式 (MOUNTING TYPE) :(2)

压缩机装运条件

TRANSPORTATION FOR COMPRESSOR

机型 (MODEL): QDZH50G

12/24V (DC)

10、包装、贮存和运输 (TRANSPORTATION FOR COMPRESSOR)

包装类型(Packing type)	一次性 (不返用) (Disposable)
运输(Transport)	火车或汽车(Train, bus, vessel)
堆码层数(Stacking layers)	最多两层(not more than two layers)
型号(Model)	QDZH50G
搬运(Moving)	保持压缩机正常和垂直状态(Keep the compressor normal and vertical status)