

**APPROVALS**



 **ENGINEERING CODE**  
562KA0204AA

 **APPROVED REFRIGERANT**  
R290

 **POWER SUPPLY**  
220 - 240V 50Hz ~

 **STANDARD CONDITIONS**  
ASHRAE

 **APPLICATION**  
LBP

 **COOLING CAPACITY**  
666 W

 **EFFICIENCY**  
1.65 W/W

DATA

### General Data

<b>Weight</b>	20.9 Kg
<b>Height</b>	296 mm
<b>Length</b>	465 mm
<b>Width</b>	340 mm
<b>Power Supply</b>	220 - 240 V 50 Hz

### Electrical Data

<b>Motor Type</b>	CSR
<b>Locked Rotor Amperage (LRA)</b>	17.5 A
<b>Max Current</b>	2.79 A

### Spare Parts

<b>Condenser</b>	3R11T	2451206
<b>Valve Suction</b>	FLARE 3/8"	2110024
<b>Valve Discharge</b>	FLARE 1/4"	2110025
<b>Compressor</b>	NEU2155U	862KA51..AN
<b>Fan Kit</b>	IQ3612 254/28/5P	1996705
<b>Electrical Kit</b>	ELKOM NEU2155U	862KA5168A

## Fan Motor

Number	1
Shaft Power	-
Air Flow	595 m <sup>3</sup> /h
Blade diameter	254 mm

### PERFORMANCE

## Rated Points

Ambient Temperature	Cooling Capacity	Power Consumption	Current	Efficiency
32.00°C	666 W	403 W	2.28 A	1.65 W/W

Test Condition ASHRAE: Evaporating temp. -23.30°C, Ambient temp. 32.00°C, Return Gas 32 °C, Subcooling 3K

## Performance Curve Data

### Ambient Temperature 25°C

Evaporating Temperature °C	Cooling Capacity W	Power Consumption W	Current A	Efficiency W/W
-40	357	272	1.83	1.31
-30	564	338	2.03	1.67
-25	690	376	2.16	1.83
-23	736	390	2.21	1.88
-20	829	419	2.31	1.98
-15	982	465	2.48	2.11
-10	1147	516	2.68	2.22

Test Condition ASHRAE: Evaporating temp. -23.30°C, Ambient temp. 25.00°C, Return Gas 32 °C, Subcooling 3K

### Ambient Temperature 32°C

Evaporating Temperature °C	Cooling Capacity W	Power Consumption W	Current A	Efficiency W/W
-40	330	278	1.88	1.19
-30	512	348	2.09	1.47
-25	625	389	2.23	1.61
-23	666	403	2.28	1.65
-20	752	433	2.38	1.74
-15	892	480	2.56	1.86
-10	1045	532	2.76	1.97

Test Condition ASHRAE: Evaporating temp. -23.30°C, Ambient temp. 32.00°C, Return Gas 32 °C, Subcooling 3K

### Ambient Temperature 43°C

Evaporating Temperature °C	Cooling Capacity W	Power Consumption W	Current A	Efficiency W/W
-40	239	295	1.93	0.81
-30	399	375	2.18	1.07
-25	501	419	2.33	1.2
-23	540	434	2.39	1.24
-20	618	466	2.51	1.33
-15	747	516	2.71	1.45
-10	889	570	2.92	1.56

Test Condition ASHRAE: Evaporating temp. -23.30°C, Ambient temp. 43.00°C, Return Gas 32 °C, Subcooling 3K

### Operating Envelope

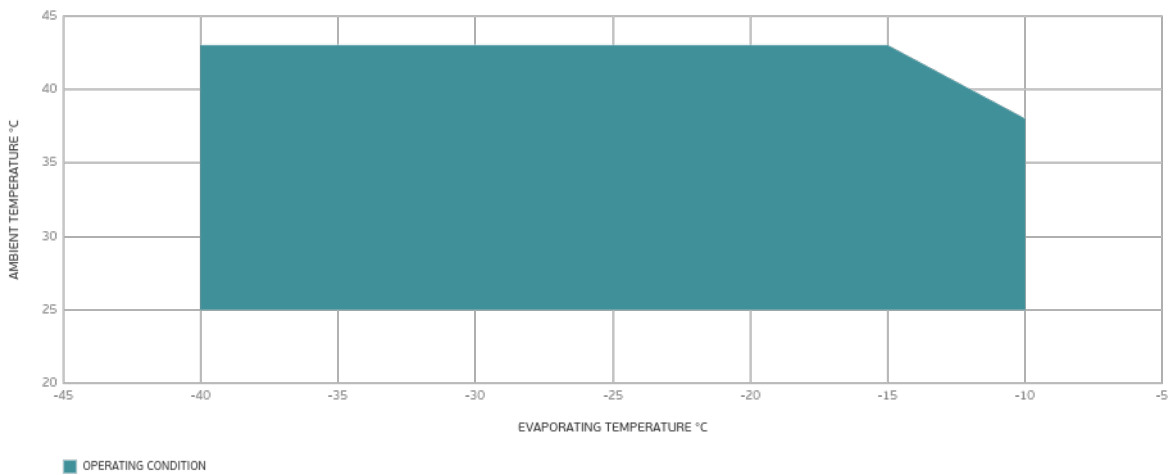

## External Dimensions

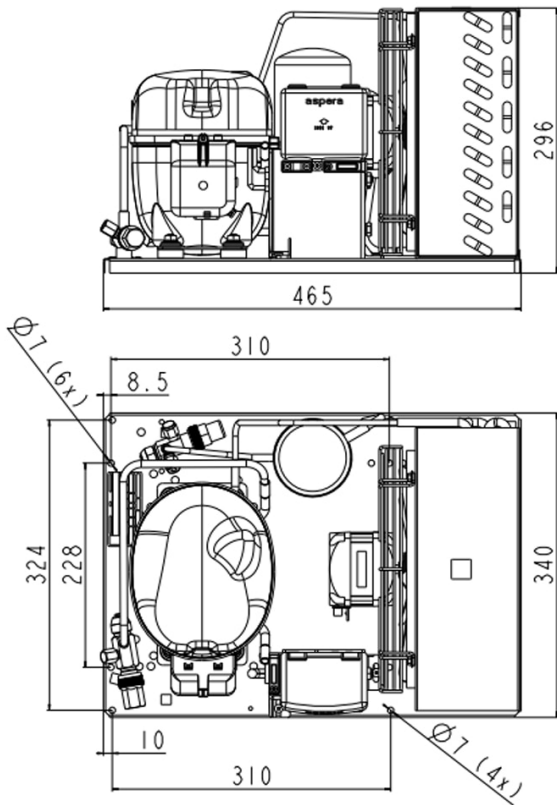

## Wiring Diagram

