

APPROVALS



 **ENGINEERING CODE**
502BA0212AA

 **APPROVED REFRIGERANT**
R290

 **POWER SUPPLY**
220 - 240V 50Hz ~

 **STANDARD CONDITIONS**
ASHRAE

 **APPLICATION**
LBP

 **COOLING CAPACITY**
920 W

 **EFFICIENCY**
1.5 W/W

DATA

General Data

Weight	26.8 Kg
Receiver	1.1 L
Height	296 mm
Length	474 mm
Width	340 mm
Power Supply	220 - 240 V 50 Hz

Electrical Data

Motor Type	CSIR
Locked Rotor Amperage (LRA)	23 A
Max Current	4.18 A

Spare Parts

Fan Kit	IQ3612 254/28/5P	1996703
Valve Discharge	FLARE 1/4"	2110025
Condenser	4R11T	2451217
Compressor	NT2170U	842BA09..AC
Electrical Kit	ELKOM NT2170U	842BA0413A
Valve Suction	FLARE 3/8"	2110056

Noise Data

Sound Power Level	61.9 dB (A)	-	-
Sound Pressure Level	at 1 m	at 5 m	at 10 m
	53.9 dB (A)	39.9 dB (A)	33.9 dB (A)

Fan Motor

Number	1
Shaft Power	-
Air Flow	595 m ³ /h
Blade diameter	254 mm

PERFORMANCE

Rated Points

Ambient Temperature	Cooling Capacity	Power Consumption	Current	Efficiency
32.00°C	920 W	612 W	3.92 A	1.5 W/W

Test Condition ASHRAE: Evaporating temp. -23.30°C, Ambient temp. 32.00°C, Return Gas 32 °C, Subcooling 3K

Performance Curve Data

Ambient Temperature 25°C

Evaporating Temperature °C	Cooling Capacity W	Power Consumption W	Current A	Efficiency W/W
-40	482	390	3.14	1.23
-30	782	506	3.51	1.55
-25	952	571	3.73	1.67
-23	1013	594	3.81	1.7
-20	1135	641	3.99	1.77
-15	1335	718	4.29	1.86
-10	1551	803	4.63	1.93

Test Condition ASHRAE: Evaporating temp. -23.30°C, Ambient temp. 25.00°C, Return Gas 32 °C, Subcooling 3K

Ambient Temperature 32°C

Evaporating Temperature °C	Cooling Capacity W	Power Consumption W	Current A	Efficiency W/W
-40	438	405	3.25	1.08
-30	711	521	3.61	1.36
-25	865	588	3.84	1.47
-23	920	612	3.92	1.5
-20	1032	660	4.1	1.56
-15	1213	740	4.42	1.64
-10	1410	828	4.78	1.7

Test Condition ASHRAE: Evaporating temp. -23.30°C, Ambient temp. 32.00°C, Return Gas 32 °C, Subcooling 3K

Ambient Temperature 43°C

Evaporating Temperature °C	Cooling Capacity W	Power Consumption W	Current A	Efficiency W/W
-40	329	401	3.24	0.82
-30	567	536	3.65	1.06
-25	701	613	3.92	1.14
-23	749	640	4.02	1.17
-20	846	697	4.23	1.21
-15	1004	789	4.6	1.27
-10	1176	891	5.02	1.32

Test Condition ASHRAE: Evaporating temp. -23.30°C, Ambient temp. 43.00°C, Return Gas 32 °C, Subcooling 3K

Operating Envelope

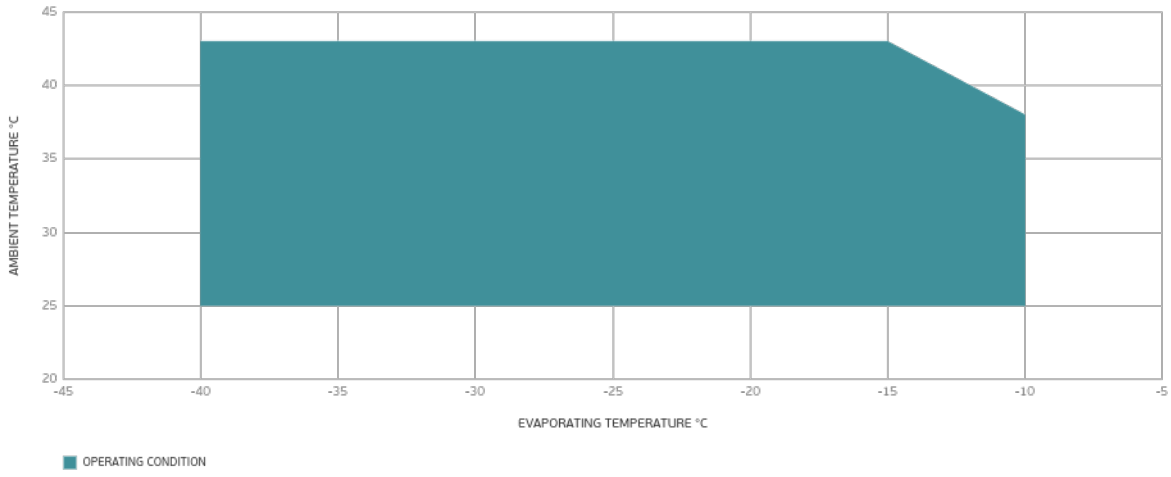

External Dimensions

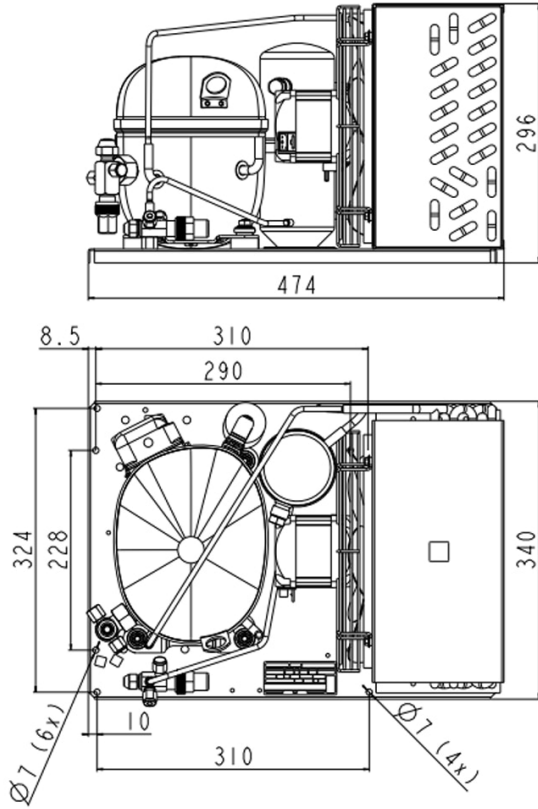

Wiring Diagram

