



APPROVALS



 **ENGINEERING CODE**
561FA0212AA

 **APPROVED REFRIGERANT**
R290

 **POWER SUPPLY**
220 - 240V 50Hz ~

 **STANDARD CONDITIONS**
ASHRAE

 **APPLICATION**
M/HBP

 **COOLING CAPACITY**
1028 W

 **EFFICIENCY**
2.97 W/W

DATA

General Data

Weight	21 Kg
Receiver	1.1 L
Height	296 mm
Length	465 mm
Width	340 mm
Power Supply	220 - 240 V 50 Hz

Electrical Data

Motor Type	CSIR
Locked Rotor Amperage (LRA)	12 A
Max Current	2.64 A

Spare Parts

Condenser	3R11T	2451206
Fan Kit	IQ3612 254/28/5P	1996703
Valve Suction	FLARE 3/8"	2110024
Valve Discharge	FLARE 1/4"	2110025
Compressor	NEK6181U	861FA51..AM
Electrical Kit	ELKOM NEK6181U	861FA5135P

Fan Motor

Number	1
Shaft Power	-
Air Flow	300 m ³ /h
Blade diameter	254 mm

PERFORMANCE

Rated Points

Ambient Temperature	Evaporating Temperature	Cooling Capacity	Power Consumption	Current	Efficiency
32.00°C	7.20°C	1028 W	346 W	2.28 A	2.97 W/W

Test Condition ASHRAE: Evaporating temp. 7.20°C, Ambient temp. 32.00°C, Return Gas 32 °C, Subcooling 3K

Performance Curve Data

Ambient Temperature 25°C

Evaporating Temperature °C	Cooling Capacity W	Power Consumption W	Current A	Efficiency W/W
-20	435	242	1.94	1.79
-15	533	258	1.99	2.07
-5	761	285	2.07	2.66
0	895	298	2.11	3
5	1047	312	2.16	3.36
7	1120	317	2.18	3.53
10	1220	325	2.21	3.75

Test Condition ASHRAE: Evaporating temp. 7.20°C, Ambient temp. 25.00°C, Return Gas 32 °C, Subcooling 3K

Ambient Temperature 32°C

Evaporating Temperature °C	Cooling Capacity W	Power Consumption W	Current A	Efficiency W/W
-20	385	254	1.97	1.52
-15	479	272	2.03	1.76
-5	694	307	2.14	2.26
0	819	323	2.19	2.54
5	960	339	2.25	2.84
7	1028	346	2.28	2.97
10	1120	355	2.32	3.15

Test Condition ASHRAE: Evaporating temp. 7.20°C, Ambient temp. 32.00°C, Return Gas 32 °C, Subcooling 3K

Ambient Temperature 43°C

Evaporating Temperature °C	Cooling Capacity W	Power Consumption W	Current A	Efficiency W/W
-20	295	265	2	1.11
-15	377	291	2.08	1.29
-5	557	339	2.24	1.64
0	662	362	2.32	1.83
5	780	385	2.41	2.02
7	836	395	2.45	2.11
10	913	408	2.51	2.24

Test Condition ASHRAE: Evaporating temp. 7.20°C, Ambient temp. 43.00°C, Return Gas 32 °C, Subcooling 3K

Operating Envelope

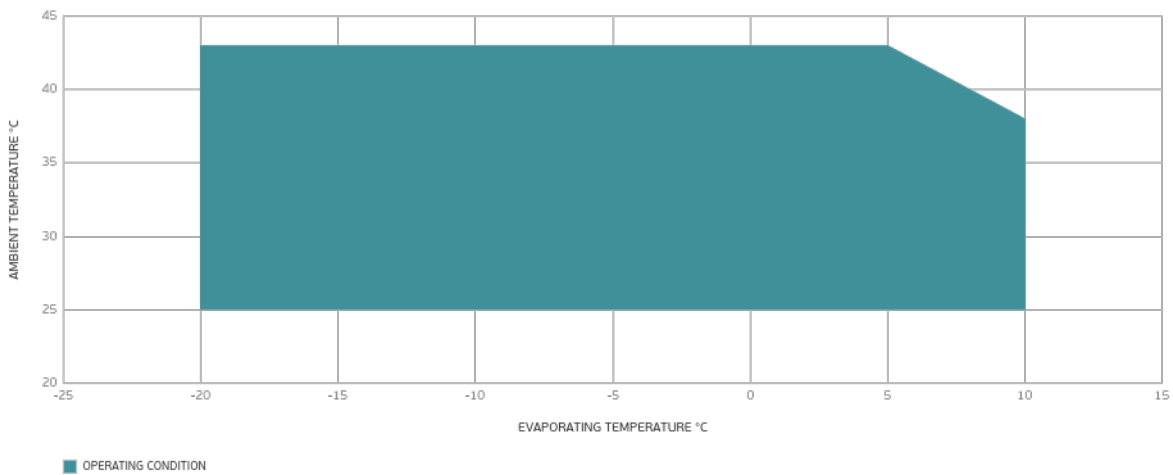

■ OPERATING CONDITION

External Dimensions

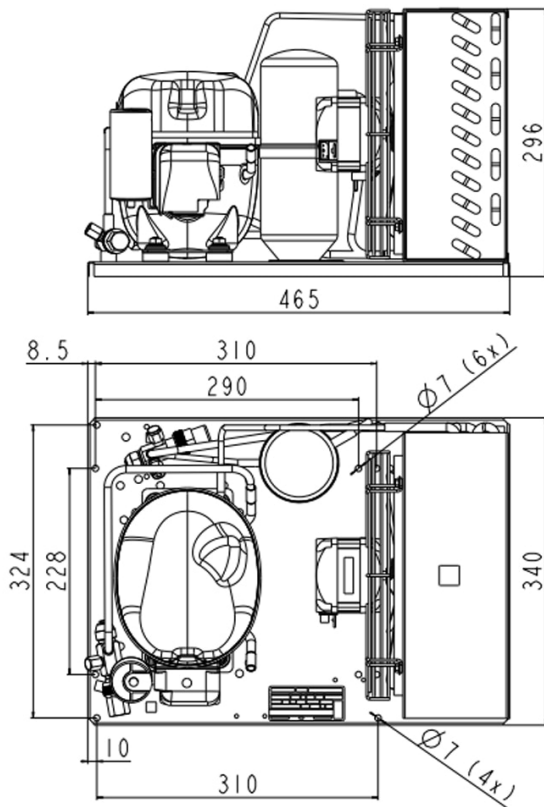

Wiring Diagram

