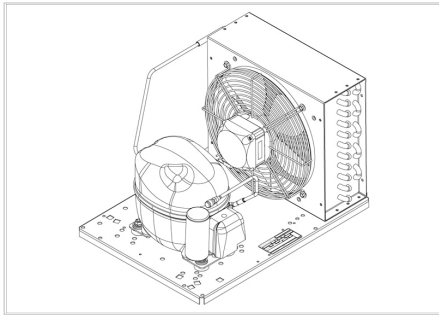

MODEL

UNEU6214Z
embraco
Nidec

APPROVALS

CE

 ECODESIGN
COMPLIANT

ENGINEERING CODE
668NA9012AA

APPROVED REFRIGERANT
R134a

POWER SUPPLY
220 - 240V 50Hz ~

STANDARD CONDITIONS
ASHRAE

APPLICATION
M/HBP

COOLING CAPACITY
1608 W

EFFICIENCY
2.1 W/W

DATA

General Data

Weight	20.6 Kg
Height	296 mm
Length	465 mm
Width	340 mm
Power Supply	220 - 240 V 50 Hz

Electrical Data

Motor Type	CSIR
Locked Rotor Amperage (LRA)	22 A
Max Current	4.63 A

Spare Parts

Condenser	3R11T	2451206
Fan Kit	16W 254/28/5B	1996579
Compressor	NEU6214Z	269NA51..AN
Electrical Kit	ELKOM NEU6214Z	269NA51M1A

Fan Motor

Number	1
Shaft Power	16 W
Air Flow	595 m ³ /h
Blade diameter	254 mm

PERFORMANCE

Rated Points

Ambient Temperature	Evaporating Temperature	Cooling Capacity	Power Consumption	Current	Efficiency
32.00°C	7.20°C	1608 W	767 W	4.39 A	2.1 W/W

Test Condition ASHRAE: Evaporating temp. 7.20°C, Ambient temp. 32.00°C, Return Gas 32 °C, Subcooling 3K

Performance Curve Data

Ambient Temperature 25°C

Evaporating Temperature °C	Cooling Capacity W	Power Consumption W	Current A	Efficiency W/W
-15	741	443	3.32	1.67
-5	1117	560	3.66	2
0	1325	632	3.9	2.09
5	1546	715	4.2	2.16
7	1648	755	4.34	2.18
10	1782	808	4.54	2.2

Test Condition ASHRAE: Evaporating temp. 7.20°C, Ambient temp. 25.00°C, Return Gas 32 °C, Subcooling 3K

Ambient Temperature 32°C

Evaporating Temperature °C	Cooling Capacity W	Power Consumption W	Current A	Efficiency W/W
-15	717	448	3.34	1.6
-5	1081	567	3.68	1.91
0	1286	642	3.93	2
5	1506	727	4.24	2.07
7	1608	767	4.39	2.1
10	1742	822	4.6	2.12

Test Condition ASHRAE: Evaporating temp. 7.20°C, Ambient temp. 32.00°C, Return Gas 32 °C, Subcooling 3K

Ambient Temperature 43°C

Evaporating Temperature °C	Cooling Capacity W	Power Consumption W	Current A	Efficiency W/W
-15	581	472	3.38	1.23
-5	906	603	3.77	1.5
0	1095	684	4.06	1.6
5	1302	775	4.4	1.68
7	1399	819	4.57	1.71
10	1527	878	4.81	1.74

Test Condition ASHRAE: Evaporating temp. 7.20°C, Ambient temp. 43.00°C, Return Gas 32 °C, Subcooling 3K

Operating Envelope

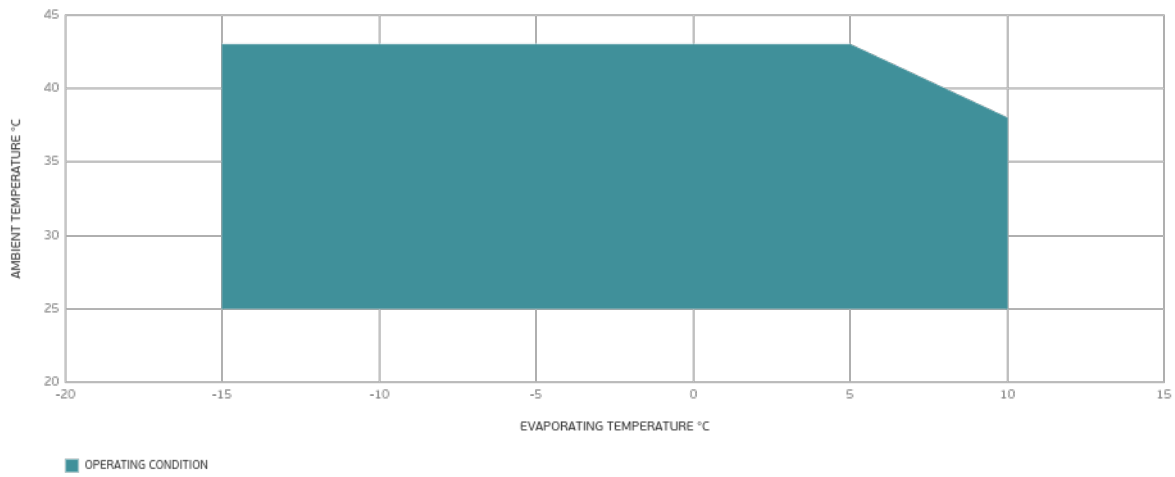

External Dimensions

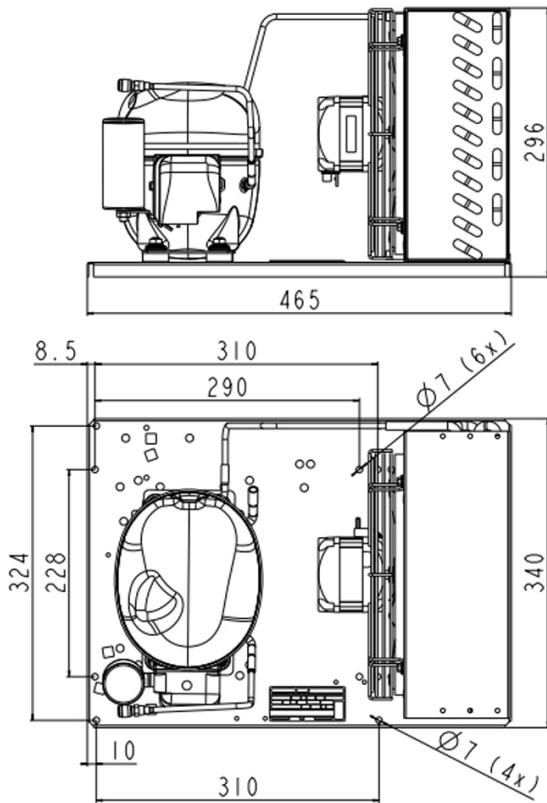

Wiring Diagram

